

20. XR125/150LEK, XL125LEK ADDENDUM

A Few Words About Safety	20-2	MAINTENANCE SCHEDULE	20-27
INTRODUCTION	20-3	STARTER MOTOR (XR150LEK).....	20-28
SERVICE RULES.....	20-4	PILOT SCREW ADJUSTMENT.....	20-28
MODEL IDENTIFICATION	20-4	RESONATOR.....	20-29
SPECIFICATIONS.....	20-6	CYLINDER HEAD (XR150LEK)	20-30
TORQUE VALUES	20-13	PRIMARY DRIVE GEAR/BALANCER DRIVE GEAR (XR150LEK)	20-30
LUBRICATION & SEAL POINTS	20-18	BALANCER DRIVEN GEAR (XR150LEK).....	20-31
CABLE & HARNESS ROUTING	20-20	BALANCER (XR150LEK)	20-35
SIDE SHROUD	20-25	COMBINATION METER	20-35
FRONT VISOR	20-25	TURN SIGNAL RELAY	20-36
FRONT FENDER	20-26	WIRING DIAGRAMS	20-37

A Few Words About Safety

Service Information

The service and repair information contained in this manual is intended for use by qualified, professional technicians. Attempting service or repairs without the proper training, tools, and equipment could cause injury to you or others. It could also damage the vehicle or create an unsafe condition.

This manual describes the proper methods and procedures for performing service, maintenance and repairs. Some procedures require the use of specially designed tools and dedicated equipment. Any person who intends to use a replacement part, service procedure or a tool that is not recommended by Honda, must determine the risks to their personal safety and the safe operation of the vehicle.

If you need to replace a part, use genuine Honda parts with the correct part number or an equivalent part. We strongly recommend that you do not use replacement parts of inferior quality.

For Your Customer's Safety

Proper service and maintenance are essential to the customer's safety and the reliability of the vehicle. Any error or oversight while servicing a vehicle can result in faulty operation, damage to the vehicle, or injury to others.

⚠ WARNING

Improper service or repairs can create an unsafe condition that can cause your customer to be seriously hurt or killed.

Follow the procedures and precautions in this manual and other service materials carefully.

For Your Safety

Because this manual is intended for the professional service technician, we do not provide warnings about many basic shop safety practices (e.g., Hot parts—wear gloves). If you have not received shop safety training or do not feel confident about your knowledge of safe servicing practice, we recommended that you do not attempt to perform the procedures described in this manual.

Some of the most important general service safety precautions are given below. However, we cannot warn you of every conceivable hazard that can arise in performing service and repair procedures. Only you can decide whether or not you should perform a given task.

⚠ WARNING

Failure to properly follow instructions and precautions can cause you to be seriously hurt or killed.

Follow the procedures and precautions in this manual carefully.

Important Safety Precautions

Make sure you have a clear understanding of all basic shop safety practices and that you are wearing appropriate clothing and using safety equipment. When performing any service task, be especially careful of the following:

- Read all of the instructions before you begin, and make sure you have the tools, the replacement or repair parts, and the skills required to perform the tasks safely and completely.
- Protect your eyes by using proper safety glasses, goggles or face shields any time you hammer, drill, grind, pry or work around pressurized air or liquids, and springs or other stored-energy components. If there is any doubt, put on eye protection.
- Use other protective wear when necessary, for example gloves or safety shoes. Handling hot or sharp parts can cause severe burns or cuts. Before you grab something that looks like it can hurt you, stop and put on gloves.
- Protect yourself and others whenever you have the vehicle up in the air. Any time you lift the vehicle, either with a hoist or a jack, make sure that it is always securely supported. Use jack stands.

Make sure the engine is off before you begin any servicing procedures, unless the instruction tells you to do otherwise. This will help eliminate several potential hazards:

- Carbon monoxide poisoning from engine exhaust. Be sure there is adequate ventilation whenever you run the engine
- Burns from hot parts or coolant. Let the engine and exhaust system cool before working in those areas.
- Injury from moving parts. If the instruction tells you to run the engine, be sure your hands, fingers and clothing are out of the way.

Gasoline vapors and hydrogen gases from batteries are explosive. To reduce the possibility of a fire or explosion, be careful when working around gasoline or batteries.

- Use only a nonflammable solvent, not gasoline, to clean parts.
- Never drain or store gasoline in an open container.
- Keep all cigarettes, sparks and flames away from the battery and all fuel-related parts.

INTRODUCTION

This addendum contains information for XR125/150LEK and XL125LEK-E.

Refer to XR125LK/125LEK and XL125LK SHOP MANUAL (No.62KRHM0) for service procedures and data not included in this addendum.

Your safety, and the safety of others, is very important. To help you make informed decisions we have provided safety messages and other information throughout this manual. Of course, it is not practical or possible to warn you about all the hazards associated with servicing this vehicle.

You must use your own good judgement.

You will find important safety information in a variety of forms including:

- Safety Labels – on the vehicle
- Safety Messages – preceded by a safety alert symbol  and one of three signal words, DANGER, WARNING, or CAUTION. These signal words mean:

 DANGER You WILL be KILLED or SERIOUSLY HURT if you don't follow instructions.

 WARNING You CAN be KILLED or SERIOUSLY HURT if you don't follow instructions.

 CAUTION You CAN be HURT if you don't follow instructions.

- Instructions – how to service this vehicle correctly and safely.

As you read this manual, you will find information that is preceded by a **NOTICE** symbol. The purpose of this message is to help prevent damage to your vehicle, other property, or the environment.

ALL INFORMATION, ILLUSTRATIONS, DIRECTIONS AND SPECIFICATIONS INCLUDED IN THIS PUBLICATION ARE BASED ON THE LATEST PRODUCT INFORMATION AVAILABLE AT THE TIME OF APPROVAL FOR PRINTING. Honda Motor Co., Ltd. RESERVES THE RIGHT TO MAKE CHANGES AT ANY TIME WITHOUT NOTICE AND WITHOUT INCURRING ANY OBLIGATION WHATSOEVER. NO PART OF THIS PUBLICATION MAY BE REPRODUCED WITHOUT WRITTEN PERMISSION. THIS MANUAL IS WRITTEN FOR PERSONS WHO HAVE ACQUIRED BASIC KNOWLEDGE OF MAINTENANCE ON Honda MOTORCYCLES, MOTOR SCOOTERS OR ATVS.

© **Honda Motor Co., Ltd.**
SERVICE PUBLICATION OFFICE

Date of Issue: February, 2014

SERVICE RULES

1. Use genuine Honda or Honda-recommended parts and lubricants or their equivalents. Parts that do not meet Honda's design specifications may cause damage to the motorcycle.
2. Use the special tools designed for this product to avoid damage and incorrect assembly.
3. Use only metric tools when servicing the motorcycle. Metric bolts, nuts and screws are not interchangeable with English fasteners.
4. Install new gaskets, O-rings, cotter pins, and lock plates when reassembling.
5. When tightening bolts or nuts, begin with the larger diameter or inner bolt first. Then tighten to the specified torque diagonally in incremental steps unless a particular sequence is specified.
6. Clean parts in cleaning solvent upon disassembly. Lubricate any sliding surfaces before reassembly.
7. After reassembly, check all parts for proper installation and operation.
8. Route all electrical wires as show in the Cable and Harness Routing (page 1-24).
9. Do not bend or twist control cables. Damaged control cables will not operate smoothly and may stick or bind.

MODEL IDENTIFICATION

This manual covers following types of XR125/150 and XL125 models; be sure to refer to the procedure for the appropriate version.

MODEL	CODE	REGION	Wheel size (Front/Rear)	Front brake type	Air cut-off valve	Carburetor heater	Sidestand switch
XR125LEK	DK	Common export	19/17 in	Disc	O	–	–
	III LA	Latin America	19/17 in	Disc	O	–	–
	SA	South Africa	19/17 in	Disc	O	O	–
XR150LEK	DK	Common export	19/17 in	Disc	O	–	–
	III LA	Latin America	19/17 in	Disc	O	–	–
	CO	Colombia	19/17 in	Disc	O	–	–
	PH	Philippines	19/17 in	Disc	O	–	–
	SA	South Africa	19/17 in	Disc	O	O	–
	I LA	Latin America	19/17 in	Disc	O	O	–
	NZ	New Zealand, Ukraine	19/17 in	Disc	O	O	O
	AG	Argentina	19/17 in	Disc	O	O	–
	PE	Peru	19/17 in	Disc	O	–	–
	MX	Mexico	19/17 in	Disc	O	–	–
XL125LEK	II SA	South Africa	21/18 in	Drum	O	O	–

XR150LEK shown:

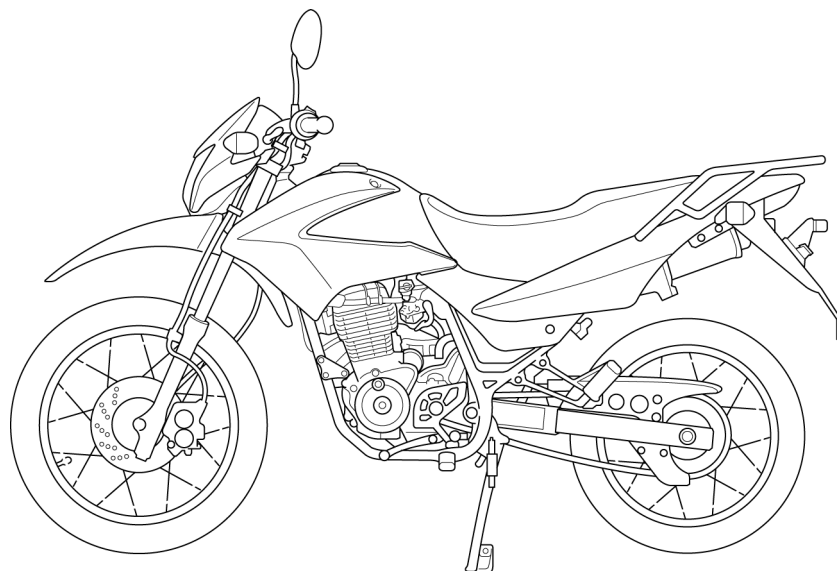

The frame serial number [1] is stamped on the right side of the steering head.

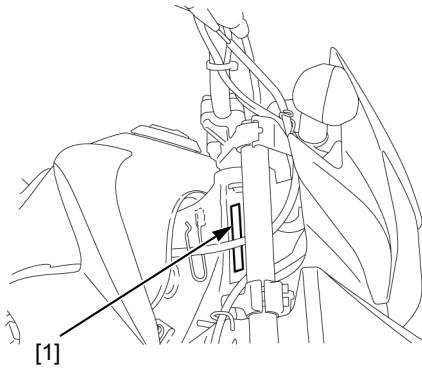

The carburetor identification number [1] is stamped on the right side of the carburetor body.

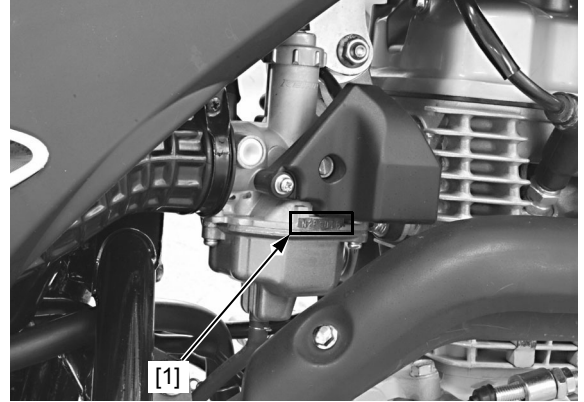

The registered number plate [1] is attached on the front side of the frame.

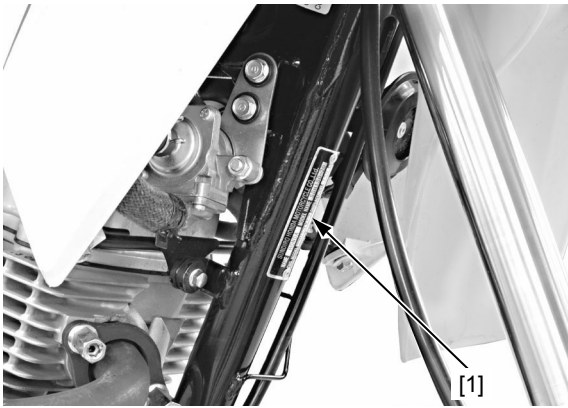

The engine serial number [1] is stamped on the lower left side of the crankcase.

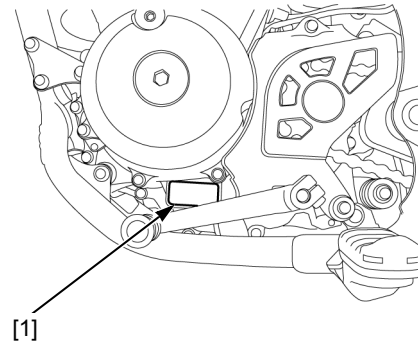

The color label [1] is attached as shown. When ordering color-coded parts, always specify the designated color code.

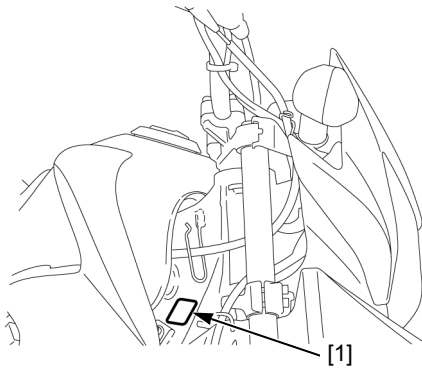

SPECIFICATIONS

GENERAL SPECIFICATIONS

ITEM		SPECIFICATION
DIMENSIONS (XR125/150LEK)	Overall length	2,091 mm (82.3 in)
	Overall width	811 mm (31.9 in)
	Overall height	1,125 mm (44.3 in)
	Wheelbase	XR125LEK 1,358 mm (53.5 in) XR150LEK 1,362 mm (53.6 in)
	Seat height	825 mm (32.5 in)
	Ground clearance	243 mm (9.6 in)
	Curb weight	XR125LEK 128 kg (282 lbs) XR150LEK 129 kg (284 lbs)
	Maximum weight capacity	155 kg (341 lbs)
	DIMENSIONS (XL125LEK)	Overall length
Overall width		827 mm (32.6 in)
Overall height		1,125 mm (44.3 in)
Wheelbase		1,358 mm (53.5 in)
Seat height		849 mm (33.4 in)
Ground clearance		263 mm (10.4 in)
Curb weight		127 kg (280 lbs)
Maximum weight capacity		155 kg (341 lbs)
FRAME (XR125/ 150LEK)	Frame type	Semi double cradle
	Front suspension	Telescopic fork
	Front wheel travel	160 mm (6.3 in)
	Rear suspension	Swingarm
	Rear wheel travel	XR125LEK 151 mm (5.9 in) XR150LEK 152 mm (6.0 in)
	Front tire size	90/90 – 19 M/C 52P
	Rear tire size	110/90 – 17 M/C 60P
	Front tire brand	C6559F (CHENG SHIN)
	Rear tire brand	C6559 (CHENG SHIN)
	Front brake	Hydraulic single disc
	Rear brake	Mechanical leading trailing
	Caster angle	27°
	Trail length	104 mm (4.1 in)
	Fuel tank capacity	12.0 liter (3.17 US gal, 2.64 Imp gal)
	Fuel tank reserve capacity	3.5 liter (0.92 US gal, 0.77 Imp gal)
FRAME (XL125LEK)	Frame type	Semi double cradle
	Front suspension	Telescopic fork
	Front wheel travel	159 mm (6.3 in)
	Rear suspension	Swingarm
	Rear wheel travel	148 mm (5.8 in)
	Front tire size	70/100 – 21 M/C 44P
	Rear tire size	100/90 – 18 M/C 56P
	Front tire brand	CM-704 (CHENG SHIN)
	Rear tire brand	CM-705 (CHENG SHIN)
	Front brake	Mechanical leading trailing
	Rear brake	Mechanical leading trailing
	Caster angle	26.8°
	Trail length	103 mm (4.1 in)
	Fuel tank capacity	12.0 liter (3.17 US gal, 2.64 Imp gal)
	Fuel tank reserve capacity	3.5 liter (0.92 US gal, 0.77 Imp gal)

XR125/150LEK, XL125LEK ADDENDUM

ITEM		SPECIFICATION	
ENGINE (XR125LEK/ XL125LEK)	Bore and stroke	52.4 x 57.8 mm (2.06 x 2.28 in)	
	Displacement	124.7 cm ³ (7.61 cu-in)	
	Valve train	Chain driven, OHC 2-valve with rocker arm	
	Compression ratio	9.2 : 1	
	Intake valve	opens at 1 mm (0.04 in) lift closes at 1 mm (0.04 in) lift	
	Exhaust valve	opens at 1 mm (0.04 in) lift closes at 1 mm (0.04 in) lift	
	Lubrication system	Forced pressure and wet sump	
	Oil pump type	Trochoid	
	Cooling system	Air cooled	
	Air filtration	Paper element (Viscous type)	
Engine dry weight	28.5 kg (62.8 lbs)		
ENGINE (XR150LEK)	Bore and stroke	57.3 x 57.8 mm (2.26 x 2.28 in)	
	Displacement	149.2 cm ³ (9.10 cu-in)	
	Valve train	Chain driven, OHC 2-valve with rocker arm	
	Compression ratio	9.5 : 1	
	Intake valve	opens at 1 mm (0.04 in) lift closes at 1 mm (0.04 in) lift	
	Exhaust valve	opens at 1 mm (0.04 in) lift closes at 1 mm (0.04 in) lift	
	Lubrication system	Forced pressure and wet sump	
	Oil pump type	Trochoid	
	Cooling system	Air cooled	
	Air filtration	Paper element (Viscous type)	
Engine dry weight	29.2 kg (64.4 lbs)		
CARBURETOR	Carburetor type	Piston valve	
	Throttle bore	20 mm (0.8 in)	
DRIVE TRAIN	Clutch system	Multi-plate, wet	
	Clutch operation system	Cable operating	
	Transmission	Constant mesh, 5-speeds	
	Primary reduction	3.350 (67/20)	
	Final reduction	XR125LEK/XL125LEK XR150LEK	
	Gear ratio	1st	3.187 (51/16)
		2nd	2.882 (49/17)
		3rd	2.785 (39/14)
		4th	1.875 (30/16)
		5th	1.409 (31/22)
Gearshift pattern	1.120 (28/25)		
	0.937 (30/32)		
ELECTRICAL	Ignition system	DC-CDI	
	Starting system	Electric starter motor with kickstarter	
	Charging system	Single phase output alternator	
	Regulator/rectifier	SCR shorted, single phase half-wave rectification	
	Lighting system	Alternator	

IGNITION SYSTEM SPECIFICATIONS

ITEM		SPECIFICATIONS	
Spark plug	XR125LEK/ XL125LEK	Standard	CPR7EA-9 (NGK)
		For extended high speed riding	CPR8EA-9 (NGK)
	XR150LEK	Standard	CPR8EA-9 (NGK)
		For extended high speed riding	CPR9EA-9 (NGK)
Spark plug gap		0.80 – 0.90 mm (0.031 – 0.035 in)	
Ignition coil primary peak voltage		100 V minimum	
Ignition pulse generator peak voltage		0.7 V minimum	
Ignition timing ("F" mark)		8° BTDC at idle	

XR125/150LEK, XL125LEK ADDENDUM

ELECTRIC STARTER SPECIFICATION

Unit: mm (in)

ITEM	STANDARD	SERVICE LIMIT
Starter motor brush length	10.00 – 10.05 (0.394 – 0.396)	6.5 (0.26)

LUBRICATION SYSTEM SPECIFICATIONS

Unit: mm (in)

ITEM	STANDARD	SERVICE LIMIT	
Engine oil capacity	After draining	1.0 liter (1.1 US qt, 0.9 Imp qt)	–
	After disassembly	1.2 liter (1.3 US qt, 1.1 Imp qt)	–
Recommended engine oil	Honda "4-stroke motorcycle oil" or an equivalent motor oil API service classification: SG or higher (except oils labeled as energy conserving on the circular API service label) Viscosity: SAE 10W-30 JASO T 903 standard: MA	–	
Oil pump rotor	Tip clearance	0.15 (0.006)	0.20 (0.008)
	Body clearance	0.15 – 0.21 (0.006 – 0.008)	0.25 (0.010)
	Side clearance	0.05 – 0.10 (0.002 – 0.004)	0.12 (0.005)

FUEL SYSTEM SPECIFICATIONS

ITEM	SPECIFICATIONS	
Carburetor identification number	XR125LEK (SA)/XL125LEK (II SA)	PDN2H
	XR125LEK (DK/III LA)	PDN2J
	XR150LEK (DK/III LA/PE/PH)	PDN2M
	XR150LEK (SA/I LA/NZ/AG)	PDN2P
	XR150LEK (CO/MX)	@
Main jet	XR125LEK/XL125LEK	#100
	XR150LEK (Except CO/MX)	#105
	XR150LEK (CO/MX)	#@
Slow jet	Except CO/MX	#35
	CO/MX	#@
Pilot screw initial opening	See page 6-12	
Float level	14 mm (0.6 in)	
Carburetor heater resistance	XR125LEK (SA)/XL125LEK (II SA)	8.2 – 12.3 Ω (25°C/77°F)
	XR150LEK (I LA/SA/AG/NZ)	11.4 – 17.0 Ω (25°C/77°F)
PAIR control valve specified vacuum	XR125LEK/XL125LEK	330 mm Hg
	XR150LEK	340 mm Hg
Idle speed	XR125LEK/XL125LEK	1,500 \pm 100 min ⁻¹ (rpm)
	XR150LEK	1,400 \pm 100 min ⁻¹ (rpm)
Throttle grip free play	2.0 – 6.0 mm (0.08 – 0.24 in)	

CYLINDER HEAD/VALVES SPECIFICATIONS

Unit: mm (in)

ITEM		STANDARD	SERVICE LIMIT
Cylinder compression at 300 min ⁻¹ (rpm)		1,275 kPa (13.0 kgf/cm ² , 185 psi)	–
Valve clearance		IN	0.08 ± 0.02 (0.003 ± 0.001)
		EX	0.12 ± 0.02 (0.005 ± 0.001)
Valve, valve guide	Valve stem O.D.	IN	4.975 – 4.990 (0.1959 – 0.1965)
		EX	4.955 – 4.970 (0.1951 – 0.1957)
	Valve guide I.D.	IN/EX	5.000 – 5.012 (0.1969 – 0.1973)
	Stem-to-guide clearance	IN	0.010 – 0.037 (0.0004 – 0.0015)
		EX	0.030 – 0.057 (0.0012 – 0.0022)
Valve seat width	IN/EX	0.9 – 1.1 (0.035 – 0.043)	
Valve spring	Free length	INNER	38.76 (1.526)
		OUTER	35.95 (1.415)
Rocker arm	Arm I.D.	IN/EX	10.000 – 10.015 (0.3937 – 0.3943)
	Shaft O.D.	IN/EX	9.972 – 9.987 (0.3926 – 0.3932)
	Arm-to-shaft clearance	IN/EX	0.013 – 0.043 (0.0005 – 0.0017)
Camshaft	Cam lobe height	IN	32.9935 – 33.2335 (1.29895 – 1.30840)
		EX	32.8804 – 33.1204 (1.29450 – 1.30395)
Cylinder head warpage		–	0.05 (0.002)

CYLINDER/PISTON SPECIFICATIONS (XR125LEK/XL125LEK)

Unit: mm (in)

ITEM		STANDARD	SERVICE LIMIT
Cylinder	I.D.	52.400 – 52.410 (2.0630 – 2.0634)	52.50 (2.067)
	Out-of-round	–	0.10 (0.004)
	Taper	–	0.10 (0.004)
	Warpage	–	0.10 (0.004)
Piston, piston pin, piston ring	Piston O.D. at 10 mm (0.4 in) from bottom		52.370 – 52.390 (2.0618 – 2.0626)
	Piston pin hole I.D.		13.002 – 13.008 (0.5119 – 0.5121)
	Piston pin O.D.		12.994 – 13.000 (0.5116 – 0.5118)
	Piston-to-piston pin clearance		0.002 – 0.014 (0.0001 – 0.0006)
	Piston ring end gap	Top	0.10 – 0.25 (0.004 – 0.010)
		Second	0.10 – 0.25 (0.004 – 0.010)
		Oil (side rail)	0.20 – 0.70 (0.008 – 0.028)
	Piston ring-to-ring groove clearance	Top	0.030 – 0.065 (0.0012 – 0.0026)
Second		0.030 – 0.065 (0.0012 – 0.0026)	
Cylinder-to-piston clearance		0.010 – 0.040 (0.0004 – 0.0016)	
Connecting rod small end I.D.		13.016 – 13.034 (0.5124 – 0.5131)	
Connecting rod-to-piston pin clearance		0.016 – 0.034 (0.0006 – 0.0013)	

XR125/150LEK, XL125LEK ADDENDUM**CYLINDER/PISTON SPECIFICATIONS (XR150LEK)**

Unit: mm (in)

ITEM		STANDARD	SERVICE LIMIT	
Cylinder	I.D.	57.300 – 57.310 (2.2559 – 2.2563)	57.40 (2.260)	
	Out-of-round	–	0.10 (0.004)	
	Taper	–	0.10 (0.004)	
	Warpage	–	0.10 (0.004)	
Piston, piston pin, piston ring	Piston O.D. at 10 mm (0.4 in) from bottom	57.280 – 57.295 (2.2551 – 2.2557)	57.20 (2.252)	
	Piston pin hole I.D.	14.002 – 14.008 (0.5513 – 0.5515)	14.04 (0.553)	
	Piston pin O.D.	13.994 – 14.000 (0.5509 – 0.5512)	13.96 (0.550)	
	Piston-to-piston pin clearance	0.002 – 0.014 (0.0001 – 0.0006)	0.04 (0.002)	
	Piston ring end gap	Top	0.10 – 0.25 (0.004 – 0.010)	0.40 (0.016)
		Second	0.10 – 0.25 (0.004 – 0.010)	0.40 (0.016)
		Oil (side rail)	0.20 – 0.70 (0.008 – 0.028)	0.85 (0.033)
	Piston ring-to-ring groove clearance	Top	0.030 – 0.060 (0.0012 – 0.0024)	0.10 (0.004)
Second		0.030 – 0.060 (0.0012 – 0.0024)	0.10 (0.004)	
Cylinder-to-piston clearance		0.005 – 0.030 (0.0002 – 0.0012)	0.09 (0.004)	
Connecting rod small end I.D.		14.010 – 14.028 (0.5516 – 0.5523)	14.06 (0.554)	
Connecting rod-to-piston pin clearance		0.010 – 0.034 (0.0004 – 0.0013)	0.10 (0.004)	

CLUTCH/GEARSHIFT LINKAGE/BALANCER GEAR SPECIFICATIONS

Unit: mm (in)

ITEM		STANDARD	SERVICE LIMIT
Clutch lever free play		10 – 20 (0.4 – 0.8)	–
Clutch	Spring free length	40.5 (1.59)	39.6 (1.56)
	Disc thickness	Disc A	2.80 – 2.90 (0.110 – 0.114)
		Disc B	2.80 – 2.90 (0.110 – 0.114)
Plate warpage		–	0.20 (0.008)
Clutch outer I.D.		23.000 – 23.021 (0.9055 – 0.9063)	23.08 (0.909)
Clutch outer guide	O.D.	22.959 – 22.980 (0.9039 – 0.9047)	22.93 (0.903)
	I.D.	16.991 – 17.009 (0.6689 – 0.6696)	17.04 (0.671)
Mainshaft O.D. at clutch outer guide		16.966 – 16.984 (0.6680 – 0.6687)	16.95 (0.667)
Kickstarter idle gear I.D.		20.500 – 20.521 (0.8071 – 0.8079)	20.58 (0.810)
Kickstarter idle gear bushing	O.D.	20.459 – 20.480 (0.8055 – 0.8063)	20.43 (0.804)
	I.D.	17.000 – 17.018 (0.6693 – 0.6700)	17.04 (0.671)
Countershaft O.D. at kickstarter idle gear		16.966 – 16.984 (0.6680 – 0.6687)	16.94 (0.667)
Kickstarter drive gear I.D.		16.016 – 16.034 (0.6305 – 0.6313)	16.06 (0.632)
Kickstarter spindle O.D. at kickstarter drive gear		15.966 – 15.984 (0.6286 – 0.6293)	15.94 (0.628)

ALTERNATOR/STARTER CLUTCH SPECIFICATION

Unit: mm (in)

ITEM	STANDARD	SERVICE LIMIT
Starter driven gear boss O.D.	45.660 – 45.673 (1.7976 – 1.7981)	45.60 (1.795)

CRANKCASE/CRANKSHAFT/TRANSMISSION/BALANCER SPECIFICATIONS

Unit: mm (in)

ITEM		STANDARD	SERVICE LIMIT
Crankshaft	Connecting rod big end radial clearance	0 – 0.008 (0 – 0.0003)	0.05 (0.002)
	Connecting rod big end side clearance	0.10 – 0.35 (0.004 – 0.014)	0.80 (0.032)
	Runout	–	0.08 (0.003)
Transmission	Gear I.D.	M4	20.000 – 20.018 (0.7874 – 0.7881)
		M5	17.000 – 17.018 (0.6693 – 0.6700)
		C1	20.500 – 20.521 (0.8071 – 0.8079)
		C2	23.020 – 23.041 (0.9063 – 0.9071)
		C3	23.025 – 23.046 (0.9065 – 0.9073)
	Bushing O.D.	C1	20.459 – 20.480 (0.8055 – 0.8063)
		C2	22.984 – 23.005 (0.9049 – 0.9057)
		C3	22.984 – 23.005 (0.9049 – 0.9057)
	Bushing I.D.	C1	17.000 – 17.018 (0.6693 – 0.6700)
		C2	20.020 – 20.041 (0.7882 – 0.7890)
		C3	20.020 – 20.041 (0.7882 – 0.7890)
	Gear-to-bushing clearance	C1	0.020 – 0.062 (0.0008 – 0.0024)
		C2	0.015 – 0.057 (0.0006 – 0.0022)
		C3	0.020 – 0.062 (0.0008 – 0.0024)
	Mainshaft O.D.	at M4	19.968 – 19.980 (0.7861 – 0.7866)
		at M5	16.968 – 16.980 (0.6680 – 0.6685)
	Countershaft O.D.	at C1	16.966 – 16.984 (0.6680 – 0.6687)
		at C2	19.978 – 19.989 (0.7865 – 0.7870)
		at C3	19.979 – 20.000 (0.7866 – 0.7874)
	Gear-to-shaft clearance	M4	0.020 – 0.050 (0.0008 – 0.0020)
		M5	0.020 – 0.050 (0.0008 – 0.0020)
Bushing-to-shaft clearance	C1	0.016 – 0.052 (0.0006 – 0.0020)	
	C2	0.031 – 0.063 (0.0012 – 0.0025)	
	C3	0.020 – 0.062 (0.0008 – 0.0024)	
Shift fork, shift fork shaft	Shift fork shaft O.D.	9.986 – 9.995 (0.3931 – 0.3944)	
	Shift fork I.D.	10.000 – 10.018 (0.3937 – 0.3944)	
	Shift fork claw thickness	4.93 – 5.00 (0.194 – 0.197)	

FRONT WHEEL/SUSPENSION/STEERING SPECIFICATIONS (XR125/150LEK)

Unit: mm (in)

ITEM		STANDARD	SERVICE LIMIT
Minimum tire thread depth		–	3.0 (0.12)
Cold tire pressure	Driver only	150 kPa (1.50 kgf/cm ² , 22 psi)	–
	Driver and passenger	150 kPa (1.50 kgf/cm ² , 22 psi)	–
Axle runout		–	0.20 (0.008)
Wheel rim runout	Radial	–	2.0 (0.08)
	Axial	–	2.0 (0.08)
Fork	Spring free length	594.5 (23.41)	582.6 (22.94)
	Pipe runout	–	0.20 (0.008)
	Recommended fluid	Honda ULTRA CUSHION OIL 10W or equivalent	–
	Fluid level	179 (7.0)	–
	Fluid capacity	180 ± 2.5 cm ³ (6.1 ± 0.08 US oz, 6.3 ± 0.09 Imp oz)	–
Steering head bearing pre-load		11.8 – 17.7 N (1.2 – 1.8 kgf, 2.6 – 4.0 lbf)	–

XR125/150LEK, XL125LEK ADDENDUM

FRONT WHEEL/BRAKE/SUSPENSION/STEERING SPECIFICATIONS (XL125LEK)

Unit: mm (in)

ITEM		STANDARD	SERVICE LIMIT
Minimum tire thread depth		–	3.0 (0.12)
Cold tire pressure	Driver only	150 kPa (1.50 kgf/cm ² , 22 psi)	–
	Driver and passenger	150 kPa (1.50 kgf/cm ² , 22 psi)	–
Axle runout		–	0.20 (0.008)
Wheel rim runout	Radial	–	2.0 (0.08)
	Axial	–	2.0 (0.08)
Fork	Spring free length	605.5 (23.84)	593.4 (23.36)
	Pipe runout	–	0.20 (0.008)
	Recommended fluid	Honda ULTRA CUSHION OIL 10W or equivalent	–
	Fluid level	194 (7.6)	–
	Fluid capacity	180 ± 2.5 cm ³ (6.1 ± 0.08 US oz, 6.3 ± 0.09 Imp oz)	–
Brake	Drum I.D.	130 (5.1)	131 (5.2)
	Brake lever free play	10 – 20 (0.4 – 0.8)	–
Steering head bearing pre-load		11.8 – 17.7 N (1.2 – 1.8 kgf, 2.6 – 4.0 lbf)	–

REAR WHEEL/BRAKE/SUSPENSION SPECIFICATIONS

Unit: mm (in)

ITEM		STANDARD	SERVICE LIMIT
Minimum tire thread depth		–	3.0 (0.12)
Cold tire pressure	XR125/150LEK	Driver only	150 kPa (1.50 kgf/cm ² , 22 psi)
		Driver and passenger	200 kPa (2.00 kgf/cm ² , 29 psi)
	XL125LEK	Driver only	150 kPa (1.50 kgf/cm ² , 22 psi)
		Driver and passenger	225 kPa (2.25 kgf/cm ² , 33 psi)
Axle runout		–	0.20 (0.008)
Wheel rim runout	Radial	–	2.0 (0.08)
	Axial	–	2.0 (0.08)
Drive chain	Size/link	428/130	–
	Slack	20 – 30 (0.8 – 1.2)	–
Brake	Drum I.D.	110 (4.3)	111 (4.4)
	Brake pedal free play	15 – 25 (0.6 – 1.0)	–

HYDRAULIC BRAKE SPECIFICATIONS (XR125/150LEK)

Unit: mm (in)

ITEM	STANDARD	SERVICE LIMIT
Specified brake fluid	DOT 3 or DOT 4	–
Brake pad wear indicator	–	To groove
Brake disc thickness	4.0 (0.16)	3.5 (0.14)
Brake disc runout	–	0.30 (0.012)
Master cylinder I.D.	12.700 – 12.743 (0.5000 – 0.5017)	12.755 (0.5022)
Master piston O.D.	12.657 – 12.684 (0.4983 – 0.4994)	12.645 (0.4978)
Caliper cylinder I.D.	27.000 – 27.050 (1.0630 – 1.0650)	27.060 (1.0654)
Caliper piston O.D.	26.918 – 26.968 (1.0598 – 1.0617)	26.91 (1.059)

BATTERY/CHARGING SYSTEM SPECIFICATIONS

ITEM		SPECIFICATIONS	
Battery	Type	YTX5L-BS	
	Capacity	12 V – 4 Ah (10 HR)	
	Current leakage	0.01 mA max.	
	Voltage (20°C/68°F)	Fully charged	Above 12.8 V
		Needs charging	Below 12.3 V
	Charging current	Normal	0.5 A/5 – 10 h
Quick		5.0 A/0.5 h	
Alternator	Capacity	0.12 kW/5,000 min ⁻¹ (rpm)	
	Charging coil resistance (20°C/68°F)	0.2 – 1.2 Ω	

LIGHTS/METER/SWITCHES SPECIFICATIONS

ITEM		SPECIFICATIONS
Bulbs	Headlight (High/Low beam)	12 V – 35/35 W
	Position light	12 V – 5 W
	Brake/taillight	12 V – 21/5 W
	License light	12 V – 5 W
	Front turn signal light	12 V – 10 W x 2
	Rear turn signal light	12 V – 10 W x 2
	Instrument light	12 V – 1.7 W
	Turn signal indicator	12 V – 3.4 W
	High beam indicator	12 V – 1.7 W
	Neutral indicator	12 V – 1.7 W
Fuse	Main fuse	15 A
	Sub fuse	10 A

TORQUE VALUES

For standard torque values (page 1-10).

ENGINE & FRAME TORQUE VALUES

FRAME/BODY PANELS/EXHAUST SYSTEM

ITEM	Q'TY	THREAD DIA. (mm)	TORQUE N·m (kgf·m, lbf·ft)	REMARKS
Exhaust pipe joint nut	2	8	18 (1.8, 13)	
Exhaust pipe protector bolt	2	6	14 (1.4, 10)	
Muffler rear mounting nut	2	8	26 (2.7, 19)	
Muffler front mounting bolt	2	8	26 (2.7, 19)	
Muffler band bolt	1	8	20 (2.0, 15)	
Exhaust pipe stud bolt	2	8	11 (1.1, 8)	See page 2-6

XR125/150LEK, XL125LEK ADDENDUM

MAINTENANCE

ITEM	Q'TY	THREAD DIA. (mm)	TORQUE N·m (kgf·m, lbf·ft)	REMARKS	
Air cleaner case cover screw	4	5	1.1 (0.1, 0.8)	Apply engine oil to the threads and seating surface. Apply grease to the threads.	
Air cleaner element screw	4	5	1.1 (0.1, 0.8)		
Spark plug	1	10	16 (1.6, 12)		
Valve adjusting lock nut	2	6	14 (1.4, 10)		
Crankshaft hole cap	1	32	15 (1.5, 11)		
Timing hole cap	1	14	10 (1.0, 7)		
Engine oil drain bolt	1	12	30 (3.1, 22)		
Oil filter rotor cover screw	3	5	4.0 (0.4, 3.0)		
Rear axle nut	1	16	93 (9.5, 69)		U-nut
Drive sprocket fixing plate bolt	2	6	12 (1.2, 9)		
Driven sprocket nut	6	8	32 (3.3, 24)		U-nut
Sidestand pivot bolt	1	10	10 (1.0, 7)		
Sidestand pivot nut	1	10	39 (4.0, 29)		U-nut
Front spoke	36	BC3.2	3.7 (0.4, 2.7)		
Rear spoke	36	BC3.2	3.7 (0.4, 2.7)		

IGNITION SYSTEM

ITEM	Q'TY	THREAD DIA. (mm)	TORQUE N·m (kgf·m, lbf·ft)	REMARKS
Timing hole cap	1	14	10 (1.0, 7)	

ELECTRIC STARTER

ITEM	Q'TY	THREAD DIA. (mm)	TORQUE N·m (kgf·m, lbf·ft)	REMARKS
Starter motor case bolt	2	–	4.9 (0.5, 3.6)	

FUEL SYSTEM

ITEM	Q'TY	THREAD DIA. (mm)	TORQUE N·m (kgf·m, lbf·ft)	REMARKS
Carburetor drain screw	1	–	1.5 (0.2, 1.1)	U-nut
Carburetor heater (I LA/SA/IISA/AG/NZ types)	1	–	4.9 (0.5, 3.6)	
Choke lever set plate screw	1	4	2.1 (0.2, 1.5)	
Slow jet	1	–	1.8 (0.2, 1.3)	
Needle jet holder	1	–	2.5 (0.3, 1.8)	
Main jet	1	–	2.1 (0.2, 1.5)	
Float chamber screw	3	4	2.1 (0.2, 1.5)	
Air cut-off valve cover screw	2	4	2.1 (0.2, 1.5)	
Fuel valve	1	18	23 (2.3, 17)	
Insulator socket bolt	2	6	12 (1.2, 9)	
Shock absorber lower mounting nut	1	10	44 (4.5, 32)	
PAIR check valve cover screw	2	4	2.1 (0.2, 1.5)	

LUBRICATION SYSTEM

ITEM	Q'TY	THREAD DIA. (mm)	TORQUE N·m (kgf·m, lbf·ft)	REMARKS
Oil pump cover screw	1	4	3.0 (0.3, 2.2)	

CYLINDER HEAD/VALVES

ITEM	Q'TY	THREAD DIA. (mm)	TORQUE N·m (kgf·m, lbf·ft)	REMARKS
Rocker arm shaft bolt	2	5	5.0 (0.5, 3.7)	Apply engine oil to the threads and seating surface. Apply grease to the threads.
Cylinder head cover bolt	2	6	10 (1.0, 7)	
Cam sprocket bolt	2	5	9.0 (0.9, 6.6)	
Tensioner lifter sealing plug	1	6	4.0 (0.4, 3.0)	
Camshaft holder special nut	4	8	32 (3.3, 24)	
Timing hole cap	1	14	10 (1.0, 7)	
Crankshaft hole cap	1	32	15 (1.5, 11)	
Spark plug	1	10	16 (1.6, 12)	

CYLINDER/PISTON

ITEM	Q'TY	THREAD DIA. (mm)	TORQUE N·m (kgf·m, lbf·ft)	REMARKS
Cylinder stud bolt	4	8	11 (1.1, 8)	See page 9-5

CLUTCH/GEARSHIFT LINKAGE/BALANCER GEAR

ITEM	Q'TY	THREAD DIA. (mm)	TORQUE N·m (kgf·m, lbf·ft)	REMARKS
Clutch center lock nut	1	14	74 (7.5, 55)	Apply engine oil to the threads and seating surface.
Clutch lifter plate bolt	4	6	12 (1.2, 9)	Apply engine oil to the threads and seating surface.
Oil filter rotor lock nut	1	14	64 (6.5, 47)	
Oil filter rotor cover screw	3	5	4.0 (0.4, 3.0)	Apply locking agent to the threads. Coating width: 6.5 ± 1.0 mm (0.26 ± 0.04 in) from tip
Gearshift cam bolt	1	6	12 (1.2, 9)	
Shift drum stopper arm bolt	1	6	12 (1.2, 9)	Apply locking agent to the threads. Coating width: 6.5 ± 1.0 mm (0.26 ± 0.04 in) from tip
Gearshift spindle return spring pin	1	8	22 (2.2, 16)	Apply locking agent to the threads. Coating width: 6.5 ± 1.0 mm (0.26 ± 0.04 in) from tip
Gearshift pedal pinch bolt	1	6	12 (1.2, 9)	Apply engine oil to the threads and seating surface.
Kickstarter arm bolt	1	8	26 (2.7, 19)	
Balancer driven gear lock nut (XR150LEK)	1	14	64 (6.5, 47)	

ALTERNATOR/STARTER CLUTCH

ITEM	Q'TY	THREAD DIA. (mm)	TORQUE N·m (kgf·m, lbf·ft)	REMARKS
Flywheel nut	1	14	74 (7.5, 55)	Apply engine oil to the threads and seating surface.
Starter clutch bolt	6	6	16 (1.6, 12)	Apply locking agent to the threads. Coating width: 6.5 ± 1.0 mm (0.26 ± 0.04 in) from tip
Stator mounting bolt	3	6	12 (1.2, 9)	Apply locking agent to the threads. Coating width: 6.5 ± 1.0 mm (0.26 ± 0.04 in) from tip
Ignition pulse generator mounting bolt	2	6	12 (1.2, 9)	
Alternator stator wire guide bolt	1	6	12 (1.2, 9)	Apply locking agent to the threads. Coating width: 6.5 ± 1.0 mm (0.26 ± 0.04 in) from tip

XR125/150LEK, XL125LEK ADDENDUM

CRANKSHAFT/TRANSMISSION/KICKSTARTER/BALANCER

ITEM	Q'TY	THREAD DIA. (mm)	TORQUE N·m (kgf·m, lbf·ft)	REMARKS
Mainshaft bearing setting plate bolt (Right crankcase side)	2	6	12 (1.2, 9)	Apply locking agent to the threads. Coating width: 6.5 ± 1.0 mm (0.26 ± 0.04 in) from tip
Push plug plate bolt	1	6	10 (1.0, 7)	Apply locking agent to the threads. Coating width: 6.5 ± 1.0 mm (0.26 ± 0.04 in) from tip

ENGINE REMOVAL/INSTALLATION

ITEM	Q'TY	THREAD DIA. (mm)	TORQUE N·m (kgf·m, lbf·ft)	REMARKS
Upper engine hanger plate nut	2	8	35 (3.6, 26)	
Upper engine hanger nut	1	8	35 (3.6, 26)	
Front engine hanger plate nut	2	8	35 (3.6, 26)	
Front engine hanger nut	1	8	35 (3.6, 26)	
Front lower engine hanger nut	1	8	35 (3.6, 26)	
Rear upper engine hanger nut	1	10	60 (6.1, 44)	
Rear lower engine hanger nut	1	10	60 (6.1, 44)	
Drive sprocket fixing plate bolt	2	6	12 (1.2, 9)	

FRONT WHEEL/BRAKE/SUSPENSION/STEERING

ITEM	Q'TY	THREAD DIA. (mm)	TORQUE N·m (kgf·m, lbf·ft)	REMARKS
Front axle nut	1	12	44 (4.5, 32)	U-nut
Brake disc mounting nut	5	6	15 (1.5, 11)	U-nut
Handlebar holder bolt	4	8	26 (2.7, 19)	
Fork socket bolt	2	8	20 (2.0, 15)	Apply locking agent to the threads.
Fork cap	2	27	22 (2.2, 16)	
Bottom bridge pinch bolt	4	8	32 (3.3, 24)	
Top bridge pinch bolt	2	8	22 (2.2, 16)	
Steering bearing adjustment nut	1	26	—	See page 14-25
Steering stem nut	1	24	103 (10.5, 76)	See page 14-25
Brake master cylinder holder bolt (XR125/150LEK)	2	6	12 (1.2, 9)	
Front brake caliper mounting bolt (XR125/150LEK)	2	8	30 (3.1, 22)	ALOC bolt; replace with new one.
Front brake lever pivot bolt (XL125LEK)	1	6	0.6 (0.1, 0.4)	
Front brake lever pivot nut (XL125LEK)	1	6	5.9 (0.6, 4.4)	
Clutch lever pivot bolt	1	6	0.6 (0.1, 0.4)	
Clutch lever pivot nut	1	6	5.9 (0.6, 4.4)	
Front brake arm nut (XL125LEK)	1	6	10 (1.0, 7)	
Front brake hose clamp bolt (XR125/150LEK)	1	6	12 (1.2, 9)	

REAR WHEEL/BRAKE/SUSPENSION

ITEM	Q'TY	THREAD DIA. (mm)	TORQUE N·m (kgf·m, lbf·ft)	REMARKS
Driven sprocket nut	6	8	32 (3.3, 24)	U-nut
Rear axle nut	1	16	93 (9.5, 69)	U-nut
Rear brake arm nut	1	6	10 (1.0, 7)	U-nut
Shock absorber upper mounting bolt	1	10	44 (4.5, 32)	ALOC bolt; replace with new one.
Shock absorber lower mounting nut	1	10	44 (4.5, 32)	U-nut
Drive chain slider screw	1	5	6.0 (0.6, 4.4)	
Swingarm pivot nut	1	14	88 (9.0, 65)	U-nut

XR125/150LEK, XL125LEK ADDENDUM

HYDRAULIC BRAKE (XR125/150LEK)

ITEM	Q'TY	THREAD DIA. (mm)	TORQUE N·m (kgf·m, lbf·ft)	REMARKS
Master cylinder reservoir cap screw	2	4	1.5 (0.2, 1.1)	Apply locking agent to the threads. Apply locking agent to the threads. ALOC bolt; replace with new one.
Brake master cylinder holder bolt	2	6	12 (1.2, 9)	
Brake lever pivot bolt	1	6	1.0 (0.1, 0.7)	
Brake lever pivot nut	1	6	5.9 (0.6, 4.4)	
Front brake light switch screw	1	4	1.2 (0.1, 0.9)	
Brake caliper main slide pin	1	8	22 (2.2, 16)	
Brake caliper sub slide pin	1	8	12.3 (1.3, 9)	
Brake pad pin	1	10	17.2 (1.8, 13)	
Pad pin plug	1	10	2.5 (0.3, 1.8)	
Brake caliper mounting bolt	2	8	30 (3.1, 22)	
Caliper bleed valve	1	8	5.4 (0.6, 4.0)	
Brake hose oil bolt	2	10	34 (3.5, 25)	

LIGHTS/METER/SWITCHES

ITEM	Q'TY	THREAD DIA. (mm)	TORQUE N·m (kgf·m, lbf·ft)	REMARKS
Turn signal lens screw	4	4	1.0 (0.1, 0.7)	
Combination meter mounting nut	3	6	9.5 (1.0, 7.0)	
Turn signal unit mounting nut	4	10	19 (1.9, 14)	

LUBRICATION & SEAL POINTS**ENGINE**

MATERIAL	LOCATION	REMARKS
Sealant (ThreeBond 1215 or equivalent)	Crankcase mating area	
	Alternator wire grommet seating surface	
Engine oil	Oil pump rotors	
	Oil filter rotor lock nut threads and seating surface	
	Oil through sliding area	
	Rocker arm shaft whole surface	
	Rocker arm inner surface and roller surface	
	Rocker arm valve adjusting nut threads	
	Cam chain whole surface	
	Camshaft holder special nut threads and seating surface	
	Cylinder inner surface	
	Piston sliding surface, piston pin hole and ring grooves	
	Piston ring whole surface	
	Clutch disc whole surface	
	Clutch center lock nut threads and seating surface	
	Clutch lifter arm sliding surface	
	Flywheel nut threads and seating surface	
	Gearshift spindle journal	
	Balancer driven gear sliding surface (XR150LEK)	
	Starter reduction gear shaft whole surface	
	Starter clutch rolling surface	
	Shift fork shaft whole surface	
	Shift drum journals and guide grooves	
	Gear teeth (primary, transmission, kickstarter)	
	Each bearing rotating area	
Each O-ring		
Multi-purpose grease	Each oil seal lip	
	Crankshaft hole cap threads	
Molybdenum disulfide oil (a mixture of 1/2 engine oil and 1/2 molybdenum disulfide grease)	Valve stem sliding surface and stem end	
	Camshaft cam whole surface	
	Piston pin outer surface	
	Clutch outer guide outer surface	
	Crankshaft connecting rod big end needle bearing	Drip 1 – 2 cm ³
	Crankshaft connecting rod small end inner surface	
	Crankshaft bearing push plug whole surface	
	Right crankshaft bearing rotating surface	
	Starter driven gear inner surface	
	M4, M5, C1, C2, C3 gear inner surface	
	C1, C2, C3 gear bushing whole surface	
	M3, C4, C5 gear shift fork groove	
	Kickstarter pinion inner surface	
Kickstarter idle gear inner bushing whole surface		
Locking agent	Shift drum stopper arm bolt threads	Coating width: 6.5 ± 1.0 mm (0.26 ± 0.04 in) from tip
	Gearshift cam bolt threads	Coating width: 6.5 ± 1.0 mm (0.26 ± 0.04 in) from tip
	Starter clutch bolt threads	Coating width: 6.5 ± 1.0 mm (0.26 ± 0.04 in) from tip
	Ignition pulse generator mounting bolt threads	Coating width: 6.5 ± 1.0 mm (0.26 ± 0.04 in) from tip
	Mainshaft bearing setting plate bolt threads	Coating width: 6.5 ± 1.0 mm (0.26 ± 0.04 in) from tip
	Alternator stator wire guide bolt threads	Coating width: 6.5 ± 1.0 mm (0.26 ± 0.04 in) from tip
	Crankshaft bearing push plug bolt threads	Coating width: 6.5 ± 1.0 mm (0.26 ± 0.04 in) from tip
Degreasing	Flywheel and crankshaft contact areas	

FRAME

MATERIAL	LOCATION	REMARKS
Urea based multipurpose grease with extreme pressure agent (example: EXCELITE EP2 manufactured by Kyodo Yushi or equivalent)	Steering head bearing	Apply each 3 – 5 g
	Steering stem dust seal lips	
Grease (Daphne EPONEX No.0 or equivalent)	Front brake panel dust seal lip (XL125LEK)	
	Speedometer pinion shaft (XL125LEK)	Apply 0.2 – 0.3 g
	Speedometer gear inner surface (XL125LEK)	Apply 0.2 – 0.3 g
	Speedometer gear teeth (XL125LEK)	Apply 3 g
	Speedometer pinion dust seal lip (XL125LEK)	
Grease (Daphne EPONEX No.2 or equivalent)	Speedometer gear teeth (XR125/150LEK)	Apply 0.5 – 1.0 g
	Speedometer gear inner surface (XR125/150LEK)	Apply 0.5 – 1.0 g
	Speedometer pinion shaft (XR125/150LEK)	
Multi-purpose grease	Front brake cam and shaft (XL125LEK)	Apply each 0.2 – 0.3 g
	Front brake panel anchor pin (XL125LEK)	Apply 0.2 – 0.3 g
	Front brake cam dust seal lip (XL125LEK)	
	Front brake lever pivot bolt sliding surface (XL125LEK)	
	Rear brake cam and shaft	Apply each 0.2 – 0.3 g
	Rear brake panel anchor pin	Apply 0.2 – 0.3 g
	Rear brake cam dust seal lip	Apply 0.2 – 0.3 g
	Front wheel dust seal lip	
	Rear wheel dust seal lip	
	Shock absorber needle bearing	
	Shock absorber dust seal lip	
	Swingarm pivot needle bearing	
	Swingarm pivot dust seal cap lip	
	Sidestand pivot	
	Rear brake pedal pivot sliding surface	
	Throttle grip pipe cable rolling area	
	Clutch lever pivot bolt sliding surface	
	Each bearing rotating area	
Silicone grease	Brake lever pivot sliding surface (XR125/150LEK)	
	Brake caliper pin sliding surface (XR125/150LEK)	
	Brake caliper bracket pin sliding surface (XR125/150LEK)	
	Brake caliper piston dust seal (XR125/150LEK)	
	Brake lever push rod contact surface (XR125/150LEK)	
DOT 3 or DOT 4 brake fluid	Brake master piston and cups (XR125/150LEK)	
	Brake caliper piston seal lip (XR125/150LEK)	
	Brake caliper piston sliding surface (XR125/150LEK)	
Honda Bond A or equivalent	Handlebar grip inner surface	
	Air cleaner case-to-connecting hose mating area	
Honda ULTRA CUSHION OIL 10W or equivalent	Fork oil seal lips	
	Fork dust seal lips	
	Fork cap O-ring	
Locking agent	Muffler protector bolt threads	
	Exhaust pipe protector bolt threads	
	Fork socket bolt threads	

CABLE & HARNESS ROUTING

XR125/150LEK

- [1]: HEADLIGHT/POSITION LIGHT 4P (BLACK) CONNECTOR
- [2]: IGNITION SWITCH 2P (BLACK) CONNECTOR
- [3]: COMBINATION METER SUB HARNESS 9P (BLACK) CONNECTOR

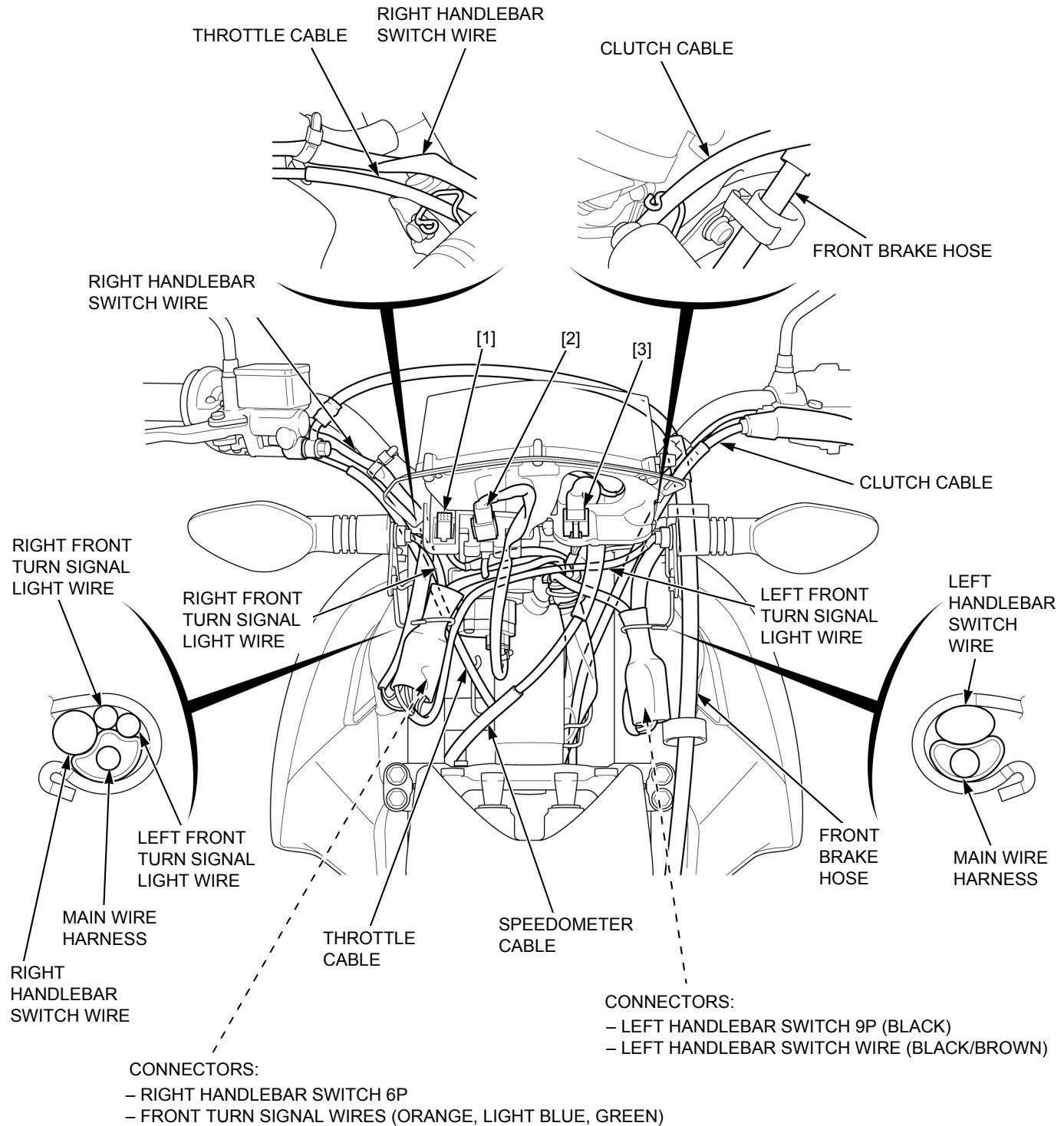

XL125LEK

- [1]: HEADLIGHT/POSITION LIGHT 4P (BLACK) CONNECTOR
- [2]: IGNITION SWITCH 2P (BLACK) CONNECTOR
- [3]: COMBINATION METER SUB HARNESS 9P (BLACK) CONNECTOR

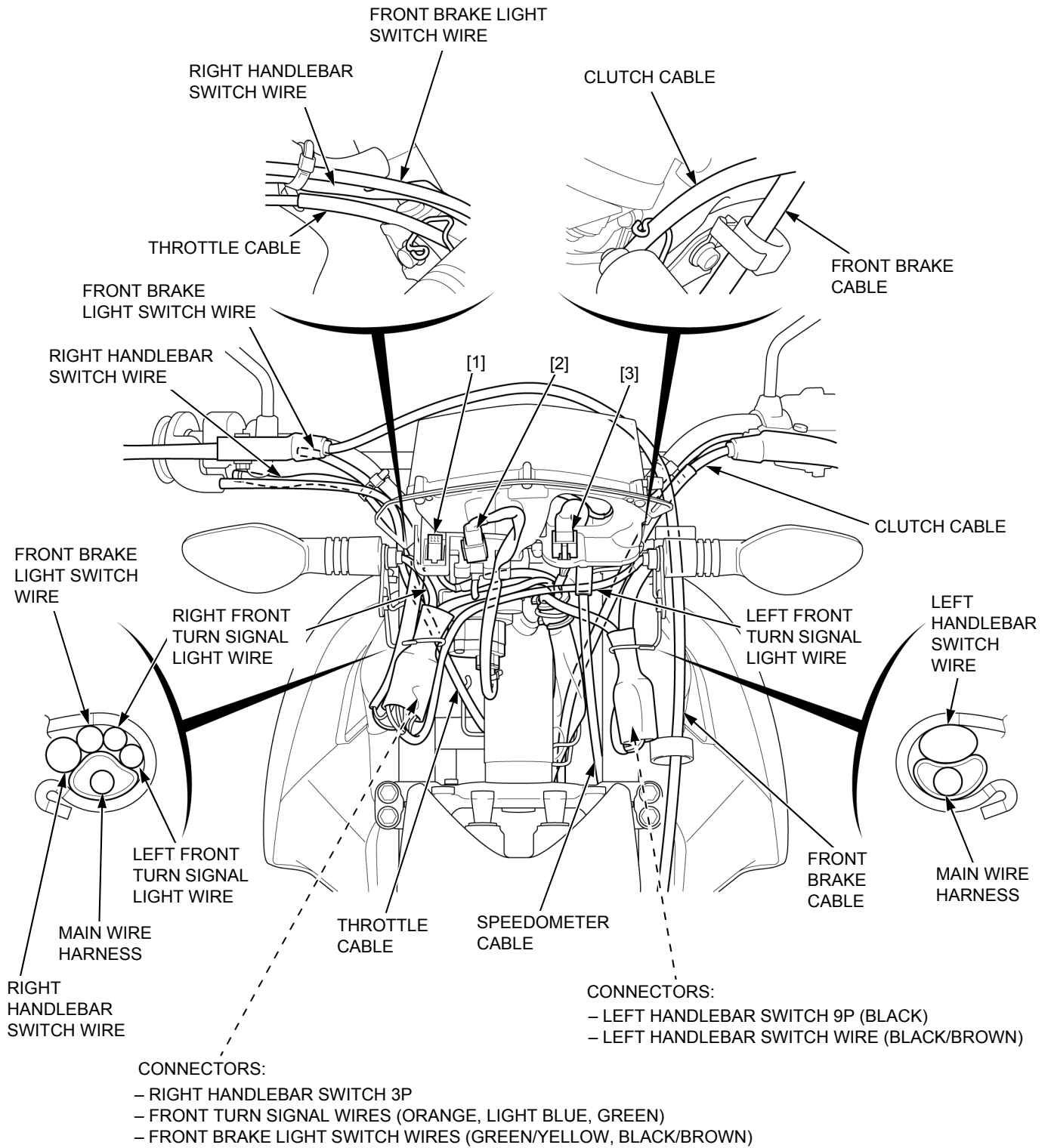

XR125/150LEK, XL125LEK ADDENDUM

XR125/150LEK

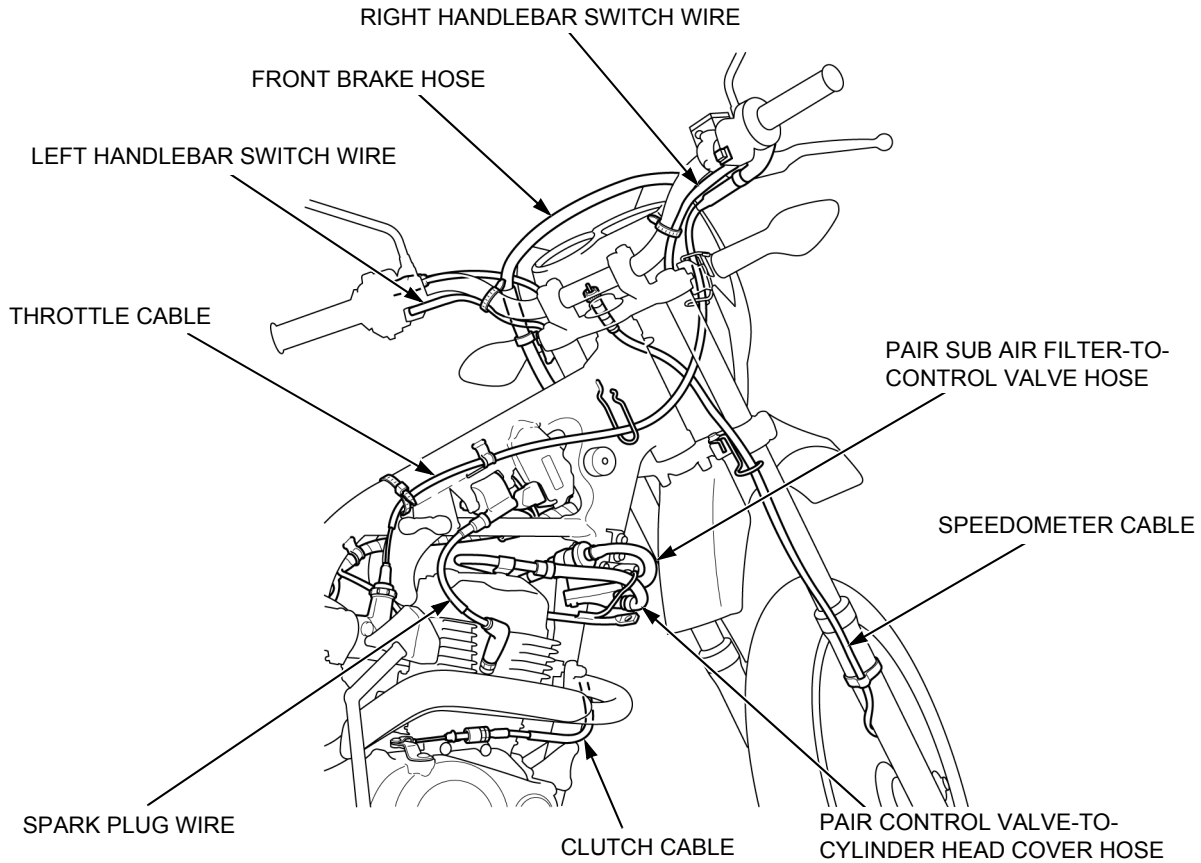

XL125LEK

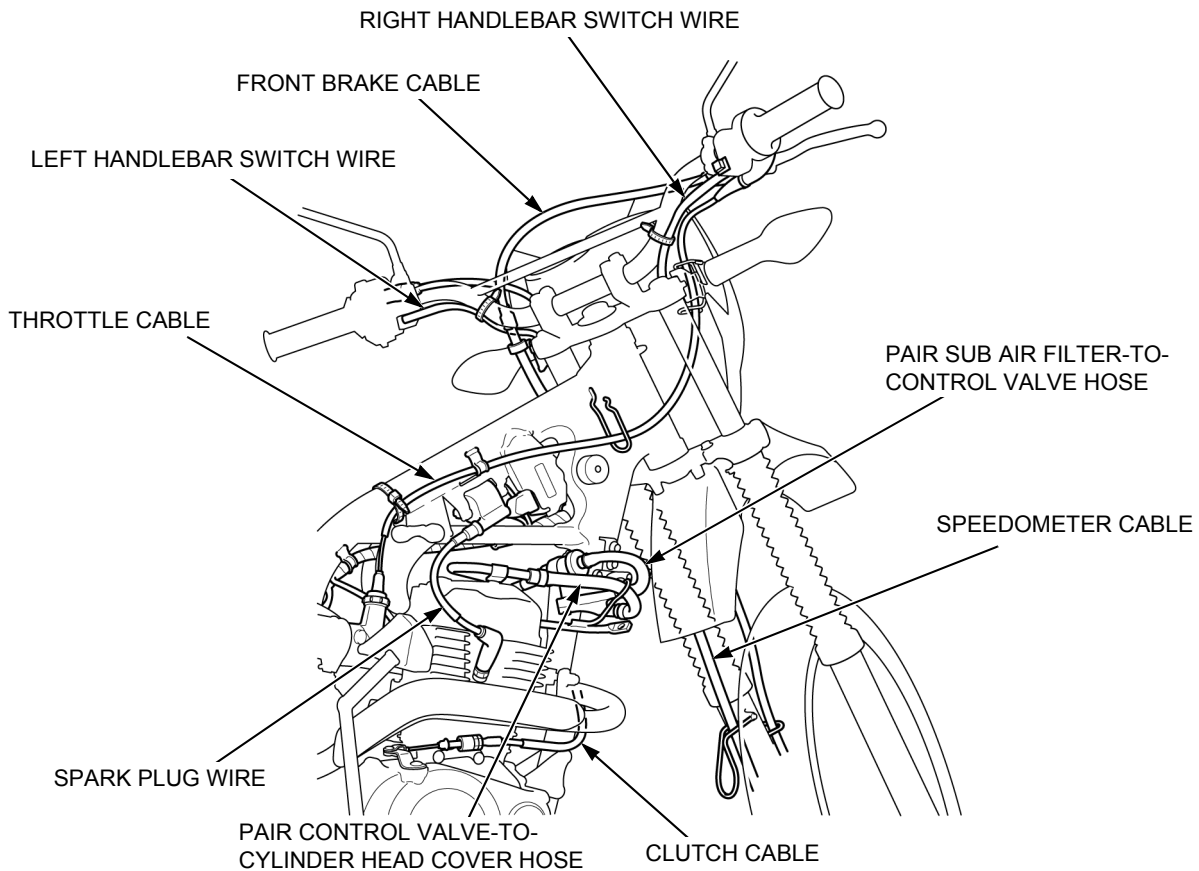

XR125/150LEK

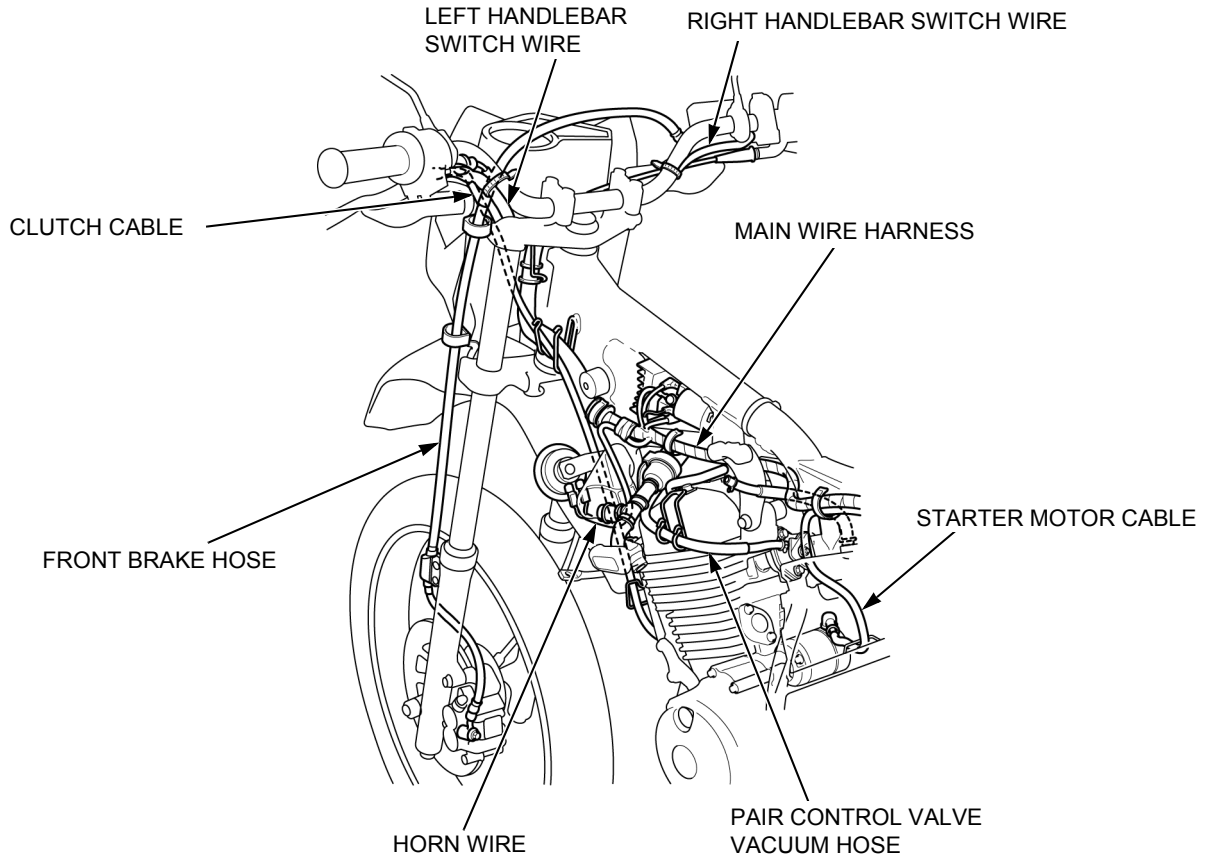

XL125LEK

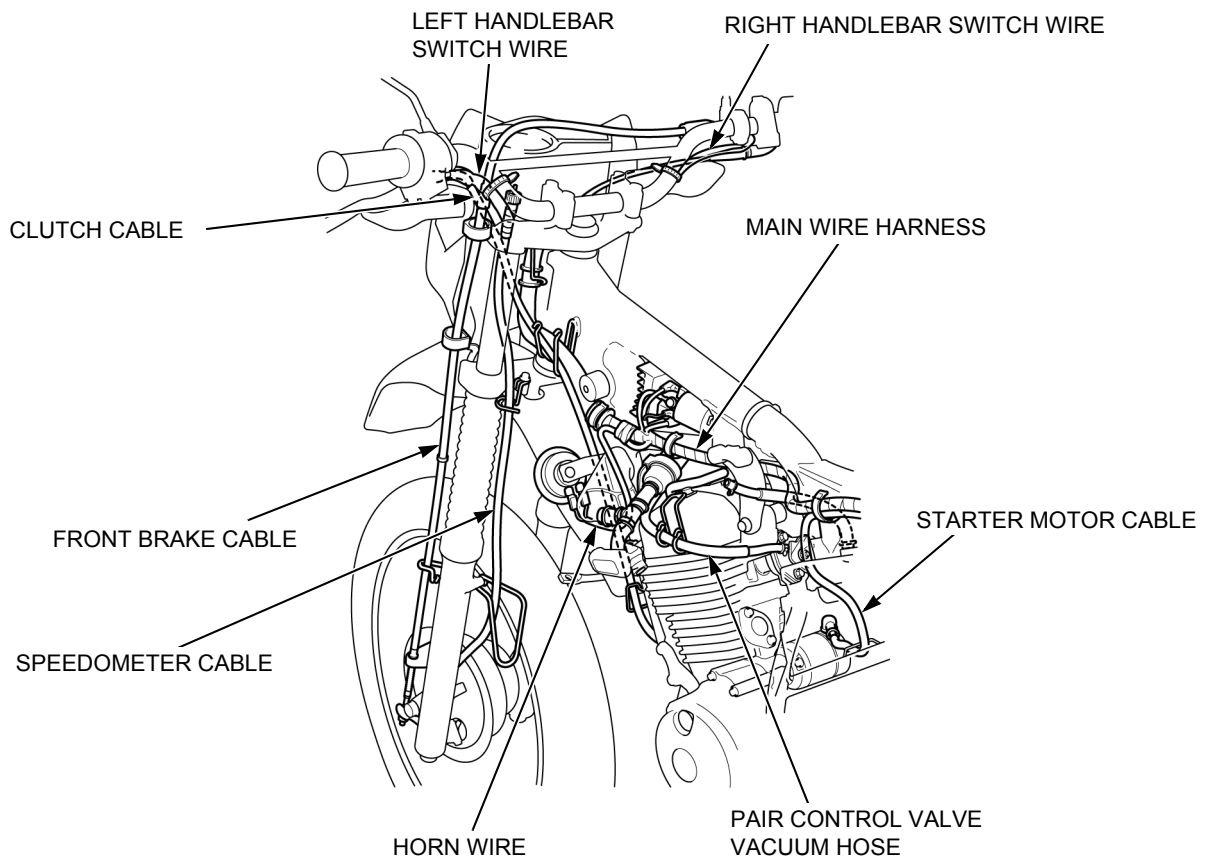

XR125/150LEK, XL125LEK ADDENDUM

ALL TYPES (NZ Type shown):

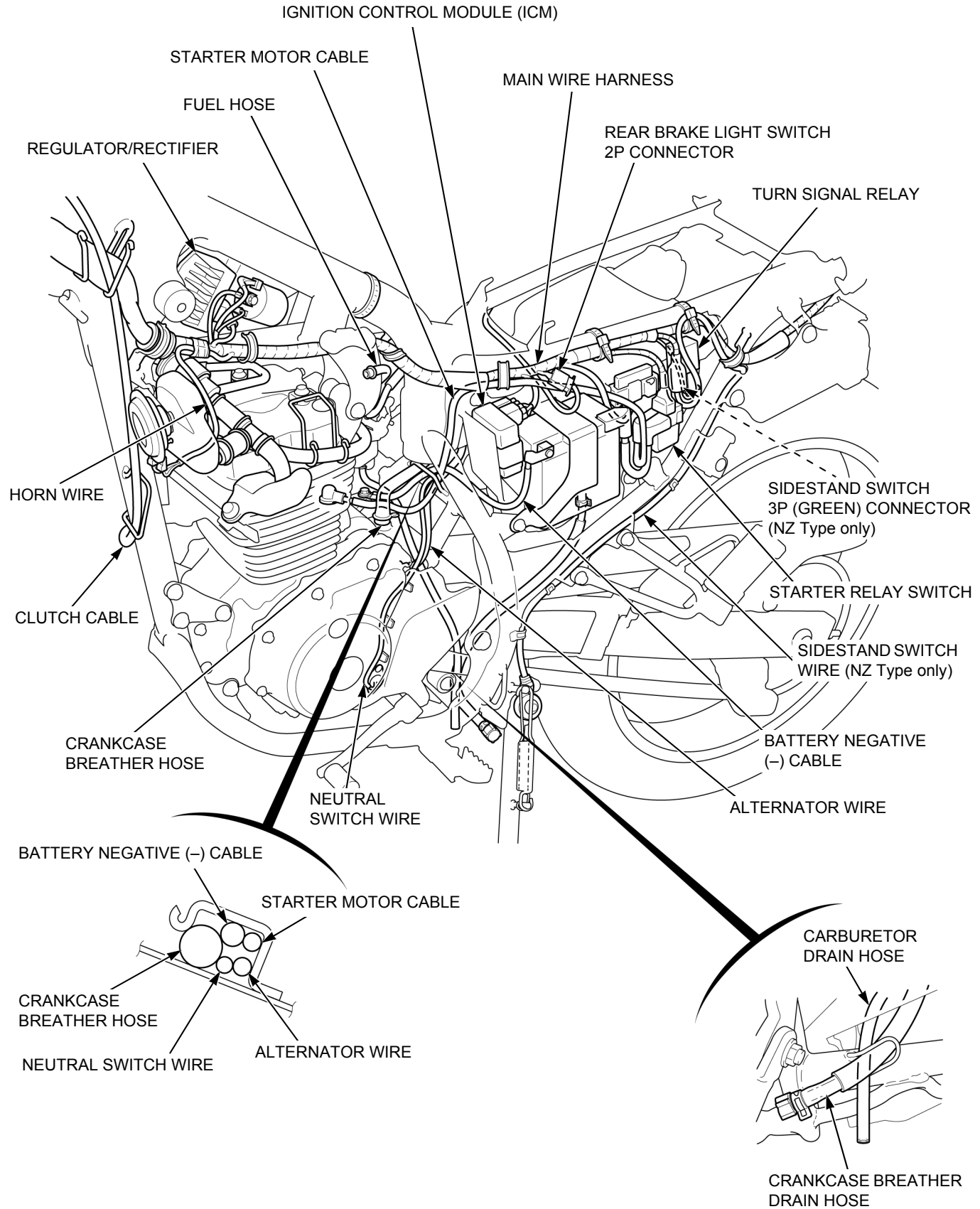

SIDE SHROUD

REMOVAL/INSTALLATION

Remove the side cover (page 2-2).

Remove the screw [1] and special bolts [2].

Remove the side shroud [3] while releasing its hole from the hook [4] on the fuel tank.

Installation is in the reverse order of removal.

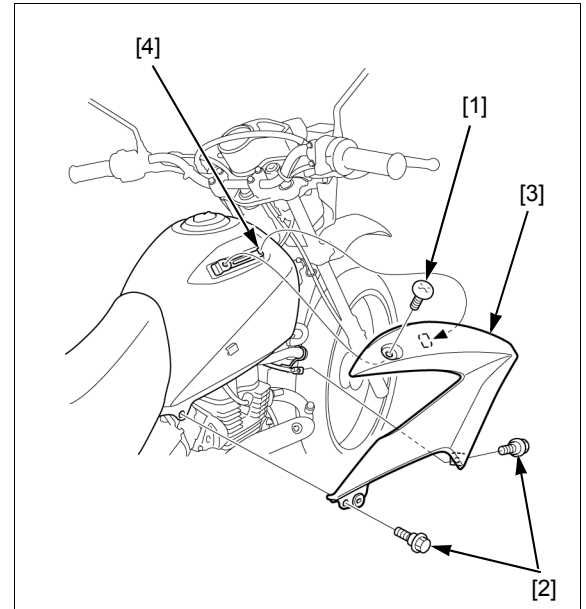

FRONT VISOR

REMOVAL/INSTALLATION

Remove the bolts [1] and front visor [2] by releasing the lower side bosses from the grommets [3], then disconnect the headlight/position light 4P (Black) connector [4].

Installation is in the reverse order of removal.

NOTE:

Install the front visor by aligning its bosses with the grommets.

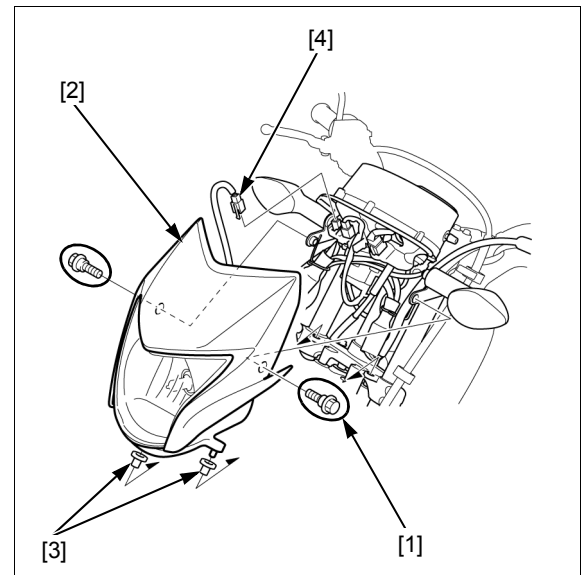

DISASSEMBLY/ASSEMBLY

Remove the headlight aim adjusting screw [1], nut [2] and spring [3].

Remove the screws [4] and plates [5], then separate the headlight unit [6].

Remove the screws [7] and separate the inner visor [8] from the front visor [9] by releasing the tabs [10].

Assembly is in the reverse order of disassembly.

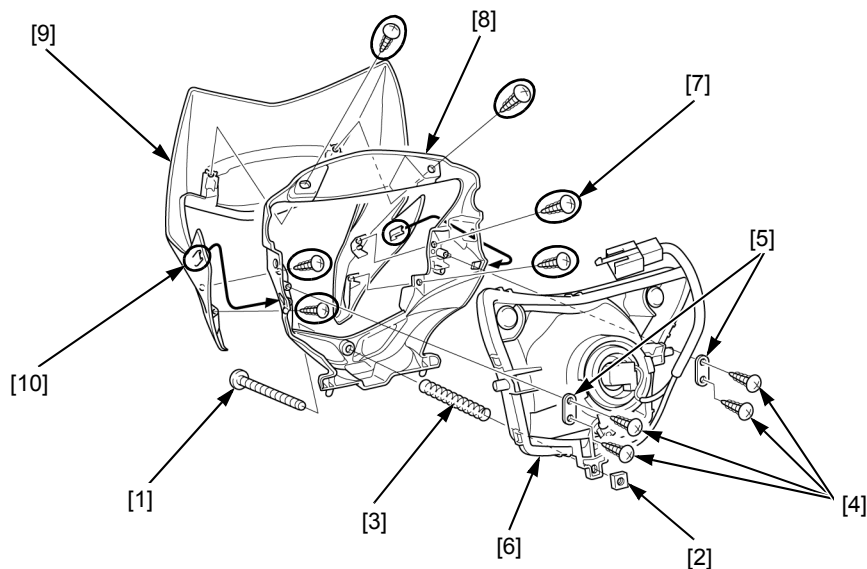

FRONT FENDER

REMOVAL/INSTALLATION

Remove the bolts [1] and washers [2].
Remove the front fender [3] and collars [4].

Installation is in the reverse order of removal.

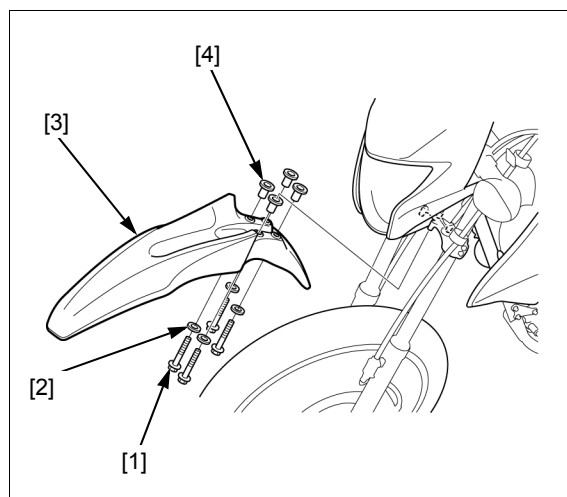

MAINTENANCE SCHEDULE

Perform the Pre-ride inspection in the Owner's Manual at each scheduled maintenance period.

I: Inspect and Clean, Adjust, Lubricate or Replace if necessary. C: Clean. R: Replace. A: Adjust. L: Lubricate.

The following items require some mechanical knowledge. Certain items (particularly those marked * and **) may require more technical information and tools. Consult a dealer.

ITEMS	FREQUENCY	NOTE	ODOMETER READING (NOTE 1)					REFER TO PAGE
			x 1,000 km	1	4	8	12	
			x 1,000 mi	0.6	2.5	5	7.5	
* FUEL LINE				I	I	I	-	
* FUEL STRAINER SCREEN				C	C	C	3-3	
* THROTTLE OPERATION				I	I	I	3-3	
* AIR CLEANER (DK/SA/II SA)		NOTE 2	EVERY 12,000 km (7,500 mi): R				3-4	
* AIR CLEANER (Except DK/SA/II SA)		NOTE 2	EVERY 16,000 km (10,000 mi): R				3-4	
CRANKCASE BREATHER		NOTE 3		C	C	C	3-5	
SPARK PLUG				I	R	I	3-5	
* VALVE CLEARANCE			I	I	I	I	3-6	
ENGINE OIL		NOTE 4	R	R	R	R	3-7	
** ENGINE OIL STRAINER SCREEN						C	3-7	
** ENGINE OIL CENTRIFUGAL FILTER						C	3-8	
* ENGINE IDLE SPEED			I	I	I	I	3-8	
* SECONDARY AIR SUPPLY SYSTEM		NOTE 2				I	3-9	
SECONDARY AIR SUPPLY PAIR FILTER		NOTE 6					3-4	
DRIVE CHAIN		NOTE 4	EVERY 1,000 km (600 mi): I, L				3-9	
DRIVE CHAIN SLIDER				I	I	I	3-11	
BRAKE FLUID (XR125/150LEK)		NOTE 5		I	I	I	3-12	
BRAKE SHOES WEAR (XL125LEK)				I	I	I	3-12	
BRAKE SHOES/PADS WEAR (XR125/150LEK)				I	I	I	3-12	
BRAKE SYSTEM			I	I	I	I	3-13	
BRAKE LIGHT SWITCH				I	I	I	3-14	
HEADLIGHT AIM				I	I	I	3-15	
CLUTCH SYSTEM			I	I	I	I	3-15	
SIDESTAND				I	I	I	3-16	
* SUSPENSION				I	I	I	3-16	
* NUTS, BOLTS, FASTENERS		NOTE 4	I		I		3-16	
** WHEELS/TIRES		NOTE 4	I	I	I	I	3-16	
** STEERING HEAD BEARINGS			I			I	3-17	

* Should be serviced by a dealer, unless the owner has proper tools and service data and is mechanically qualified.

** In the interest of safety, we recommend these items be serviced only by a dealer.

Honda recommends that a dealer should road test the motorcycle after each periodic maintenance is carried out.

NOTES:

1. At higher odometer reading, repeat at the frequency interval established here.
2. Service more frequently when riding in unusually wet or dusty areas.
3. Service more frequently when riding in rain or at full throttle.
4. Service more frequently when riding OFF-ROAD.
5. Replace every 2 years. Replacement requires mechanical skill.
6. Replace the PAIR air filter every 3 years or 24,000 km (15,000 mi). Replacement requires mechanical skill.

STARTER MOTOR (XR150LEK)

INSPECTION

For starter motor service (page 5-5).

Check the needle bearing in the motor case for wear or damage.

PILOT SCREW ADJUSTMENT

- The pilot screw are factory pre-set. Adjustment is not necessary unless the carburetor are overhauled or new pilot screw are installed.
- Use a tachometer with graduations of 50 min^{-1} (rpm) or smaller that will accurately indicate a 50 min^{-1} (rpm) change.

IDLE DROP PROCEDURE

1. Turn the pilot screw clockwise until it is lightly seated then back it out the specification given.
This is an initial setting prior to the final pilot screw adjustment.
- Damage to the pilot screw seat will occur if the pilot screw is tightened to the seat.

INITIAL OPENING:

XR125LEK/XL125LEK: 1-3/4 turns out
XR150LEK (Except CO/MX): 1-7/8 turns out
XR150LEK (CO/MX): @ turns out

TOOL:

[1] Pilot screw wrench 07908-4730002

2. Warm up the engine to operating temperature.
Stop and go riding for 10 minutes sufficient.
3. Stop the engine and connect a tachometer according to the tachometer manufacturer's instructions.
4. Disconnect the PAIR control valve vacuum hose [1], then connect the vacuum pump [2] and plug the vacuum port.

Apply the specified vacuum to the PAIR control valve vacuum hose.

SPECIFIED VACUUM:

XR125LEK/XL125LEK: 330 mmHg
XR150LEK: 340 mmHg

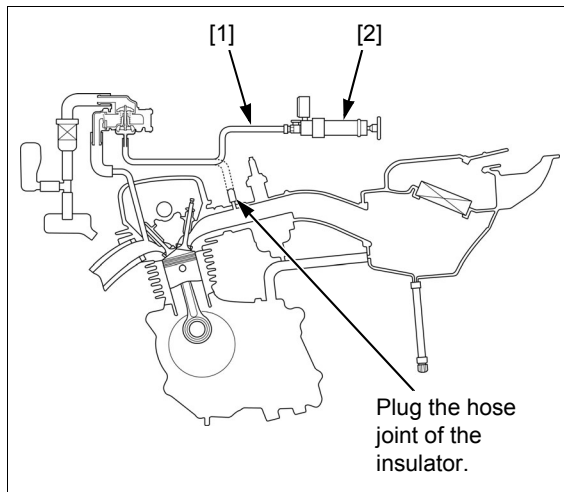
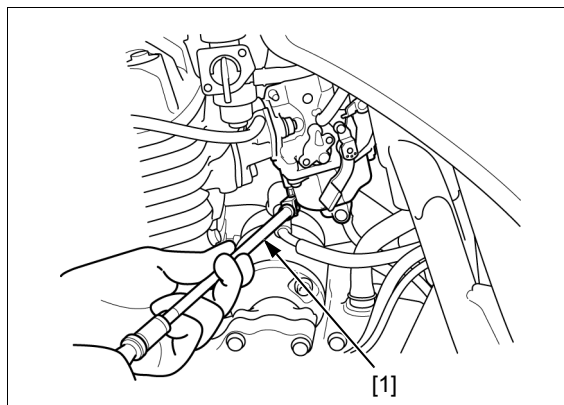

5. Start the engine and adjust the idle speed with the throttle stop screw [1].

IDLE SPEED:

XR125LEK/XL125LEK: $1,500 \pm 100 \text{ min}^{-1} \text{ (rpm)}$

XR150LEK: $1,400 \pm 100 \text{ min}^{-1} \text{ (rpm)}$

6. Turn the pilot screw inward or outward slowly to obtain the highest engine speed.
7. Lightly open the throttle 2 – 3 times, then adjust the idle speed with the throttle stop screw.
8. Turn the pilot screw in gradually until the engine speed drops by $100 \text{ min}^{-1} \text{ (rpm)}$.
9. Turn the pilot screw inward to the final opening.

FINAL OPENING:

XR125LEK/ XL125LEK: 1 turn in from the position obtained in step 8

XR150LEK (Except CO/MX): 1/2 turn in from the position obtained in step 8

XR150LEK (CO/ MX): @ turn in from the position obtained in step 8

10. Disconnect the plug from the hose joint, then remove the vacuum pump from the PAIR vacuum hose and connect the hose to the joint.
11. Readjust the idle speed with the throttle stop screw.

IDLE SPEED:

XR125LEK/XL125LEK: $1,500 \pm 100 \text{ min}^{-1} \text{ (rpm)}$

XR150LEK: $1,400 \pm 100 \text{ min}^{-1} \text{ (rpm)}$

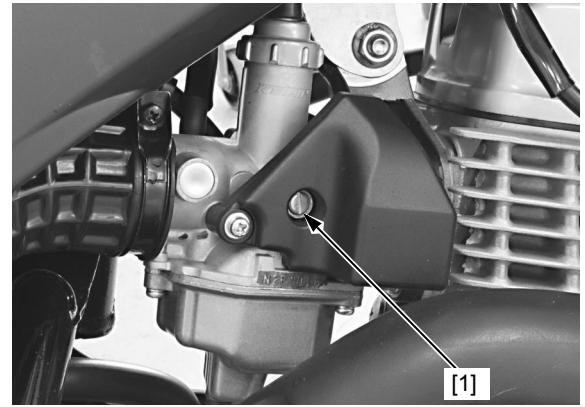

RESONATOR

REMOVAL/INSTALLATION

Remove the right side cover (page 2-2).

Loosen the band screw [1].

Remove the resonator [2] from the air cleaner connecting hose.

Installation is in the reverse order of removal.

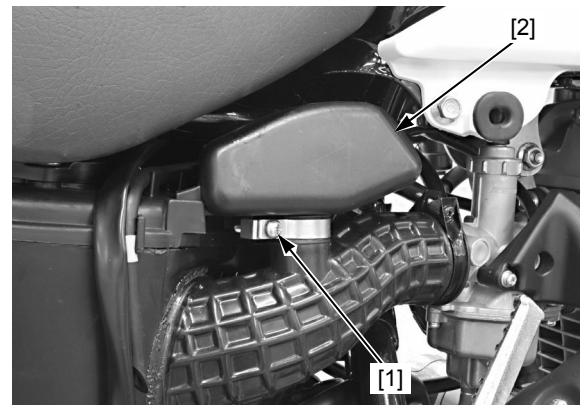

CYLINDER HEAD (XR150LEK)

VALVE SEAT REFACING

Follow the refacing manufacturer's operating instructions. Valve Seat Cutters, a grinder or equivalent valve seat refacing equipment are recommended to correct a worn valve seat.

TOOLS:

Seat cutter, 33 mm (45° IN)	07780-0010800
Seat cutter, 29 mm (45° EX)	07780-0010300
Flat cutter, 30 mm (32° IN)	07780-0012200
Flat cutter, 27 mm (32° EX)	07780-0013300
Interior cutter, 30 mm (60° IN)	07780-0014000
Interior cutter, 26 mm (60° EX)	07780-0014500
Cutter holder	07781-0010400

Using 45 degree cutter and cut the seat to the proper width.

Make sure that all pitting and irregularities are removed.

Refinish if necessary.

STANDARD SEAT WIDTH:

0.9 – 1.1 mm (0.035 – 0.043 in)

Excessive lapping pressure may deform or damage the seat. After cutting the seat, apply lapping compound to the valve face and lap the valve using light pressure. Change the angle of lapping tool [1] frequently to prevent uneven seat wear.

Lapping compound can cause damage if it enters between the valve stem and guide. After lapping, wash any residual compound off the cylinder head and valve.

Recheck the seat contact after lapping.

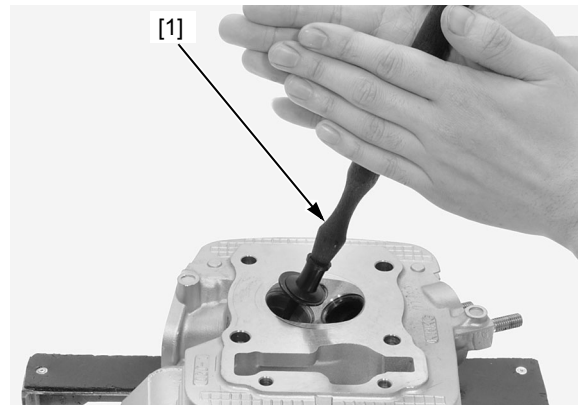
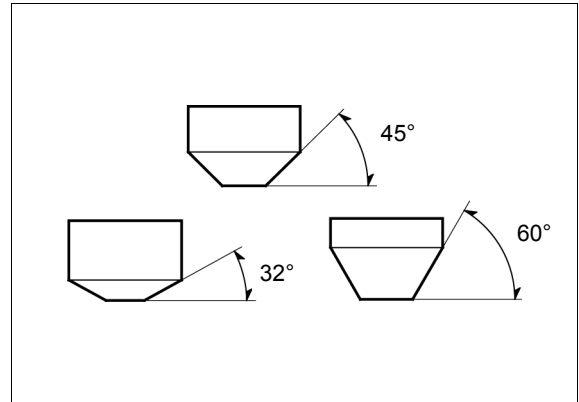

PRIMARY DRIVE GEAR/BALANCER DRIVE GEAR (XR150LEK)

REMOVAL

Remove the clutch (page 10-7).

Remove the primary drive gear [1].

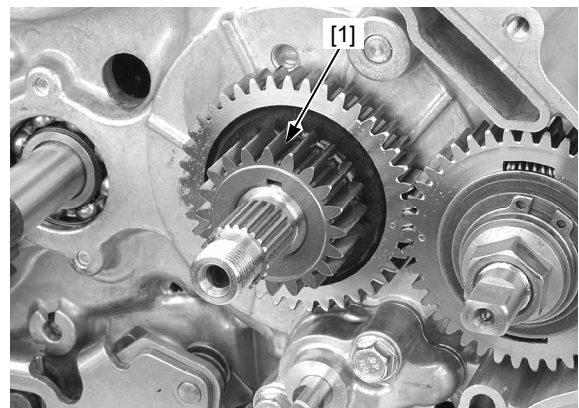

Be careful not to damage the key groove. Remove the balancer drive gear [1] and woodruff key [2].

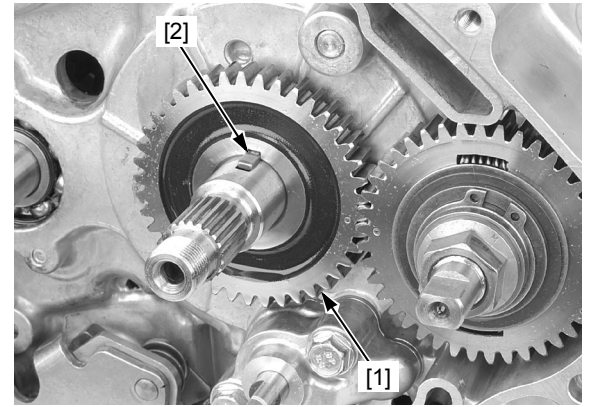

INSTALLATION

Install the woodruff key onto the crankshaft.
 Apply clean engine oil to the balancer drive gear [1].
 Install the balancer drive gear, aligning its groove with the woodruff key and also aligning the punch marks of the drive gear and driven gear.

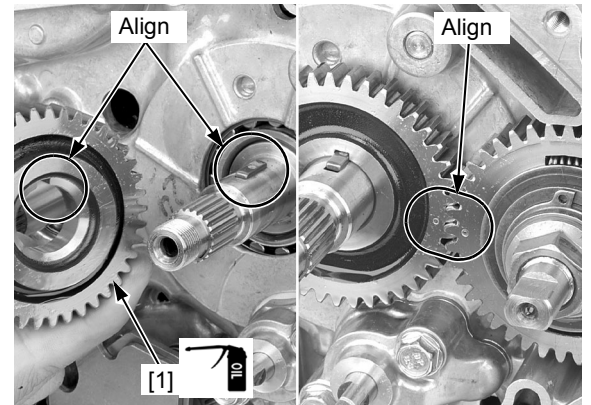

Apply clean engine oil to the primary drive gear [1] teeth.
 Install the primary drive gear, aligning its groove with the woodruff key.
 Install the clutch (page 10-8).

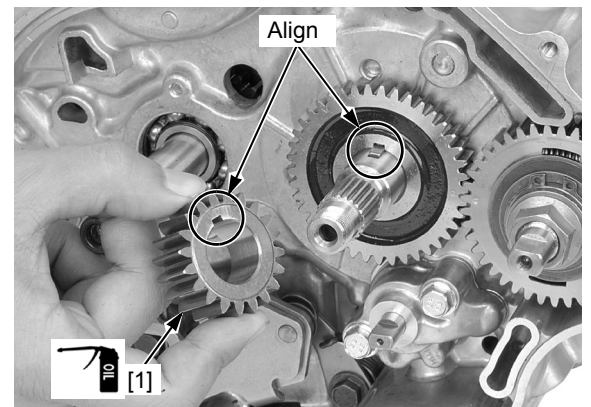

BALANCER DRIVEN GEAR (XR150LEK)

REMOVAL

Remove the right crankcase cover (page 10-4).
 Install the gear holder [1] between the balancer drive and driven gears as shown, and loosen the driven gear lock nut [2].

TOOL:
 Gear holder 07724-0010200

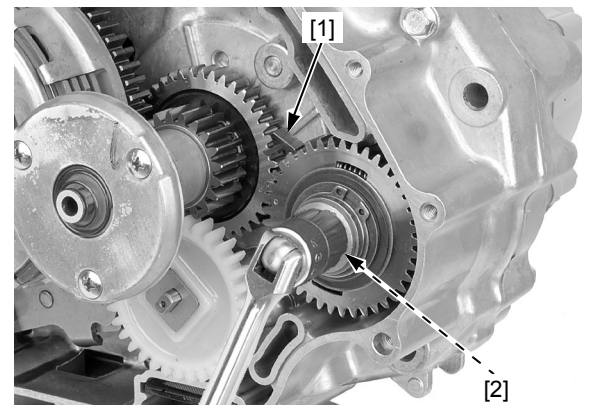

XR125/150LEK, XL125LEK ADDENDUM

Remove the lock nut [1], washer [2] and balancer driven gear [3].

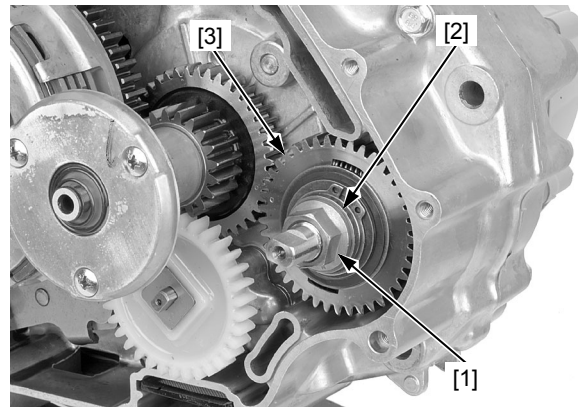

Be careful not to damage the key groove.

Remove the collar [1] and woodruff key [2].

INSTALLATION

Install the woodruff key and collar.

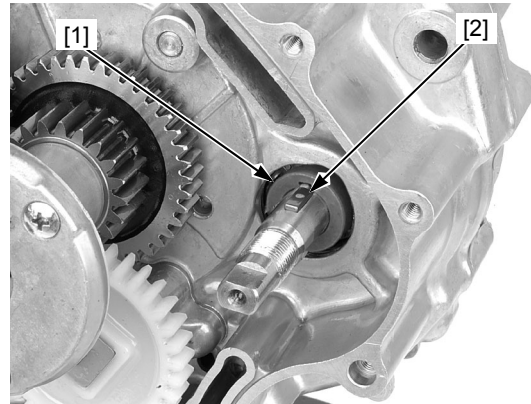

Install the balancer driven gear [1], aligning its groove with the woodruff key and also aligning the punch marks of the drive gear and driven gear.

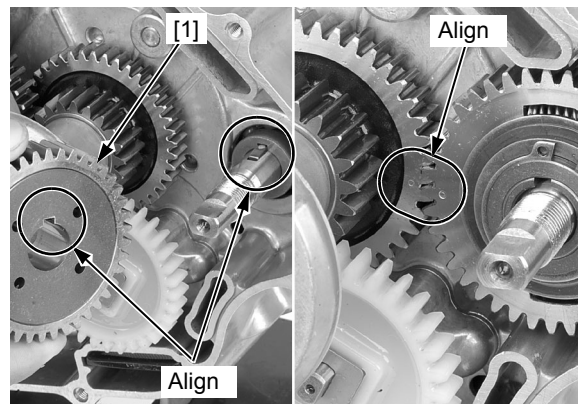

Apply clean engine oil to the lock nut [1] threads and seating surface.

Install the washer [2] and lock nut.

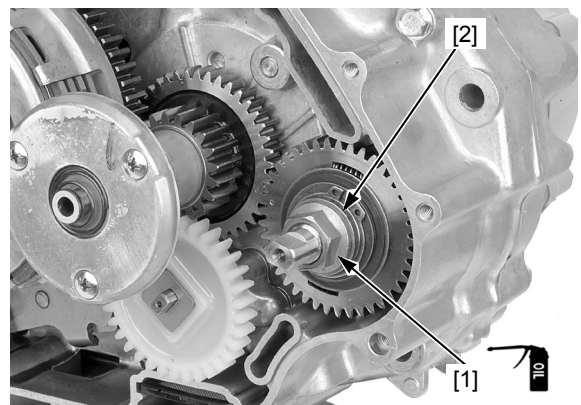

Install the gear holder [1] between the balancer drive and driven gears, and tighten the driven gear lock nut [2] to the specified torque.

TOOL:

Gear holder 07724-0010200

TORQUE: 64 N·m (6.5 kgf·m, 47 lbf·ft)

Install the right crankcase cover (page 10-4).

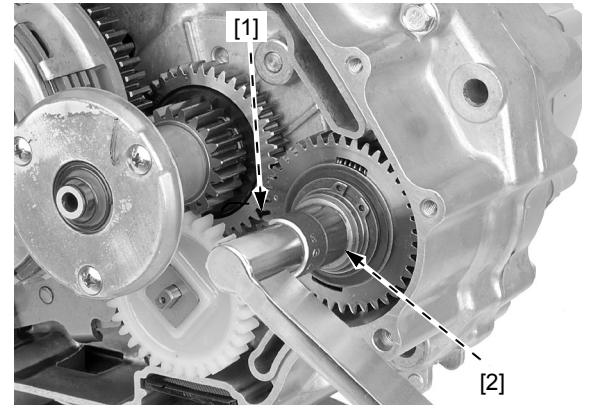

DISASSEMBLY

Remove the balancer driven gear (page 20-31).

Remove the following:

- Snap ring [1]
- Washer A [2]
- Lock washer [3]
- Washer B [4]

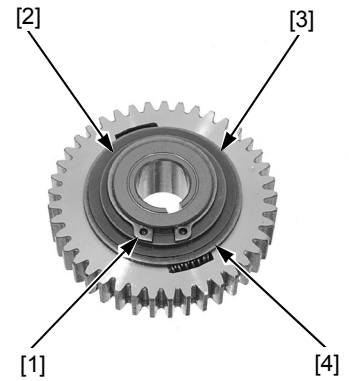

Remove the following:

- Gear case [1]
- Damper rubbers [2]
- Springs [3]

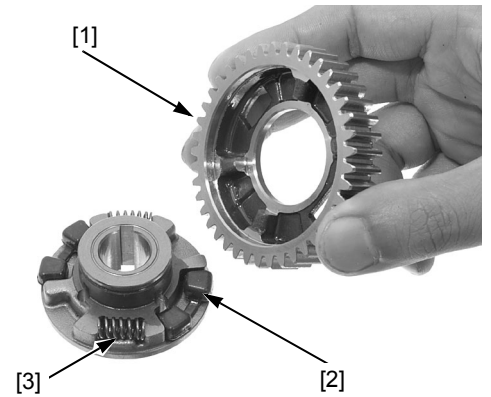

Check the springs [1] for fatigue or damage.
Check the damper rubbers [2] for wear, damage or deformation.

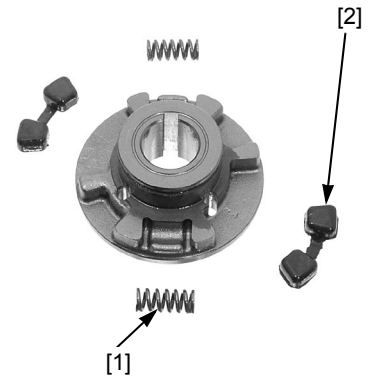

XR125/150LEK, XL125LEK ADDENDUM

Check the balancer gear [1] for wear or damage.

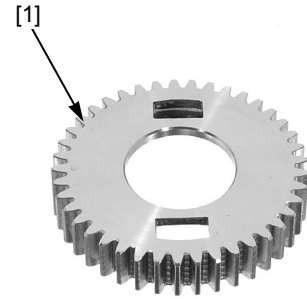

ASSEMBLY

Apply clean engine oil to the gear inner surface.

Install the damper rubbers [1] to the gear base [2].

Install the gear case [3], aligning the case tab with the damper rubbers.

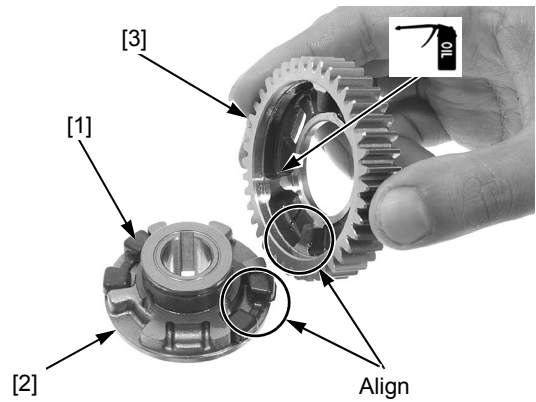

Install the spring [1] into the gear case [2].

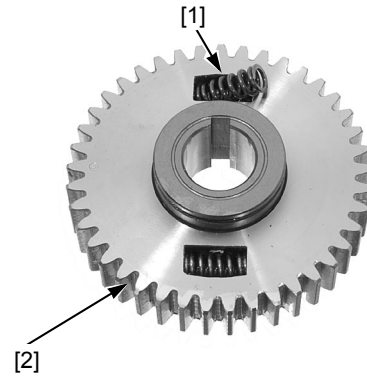

Install the lock washer with its concave side facing the driven gear.

Install the following:

- Washer B [1]
- Lock washer [2]
- Washer A [3]
- New snap ring [4]

Install the balancer driven gear (page 20-32).

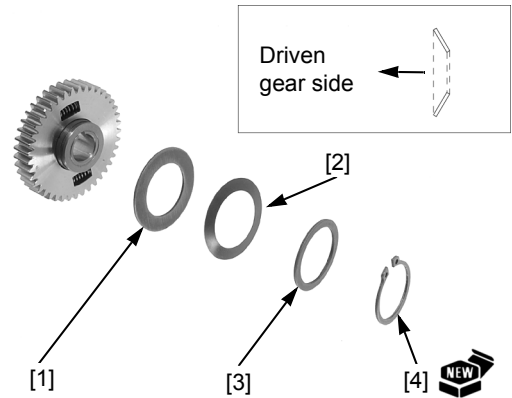

BALANCER (XR150LEK)

REMOVAL/INSTALLATION

Remove the following:

- Balancer driven gear (page 20-31)
- Primary drive gear/balancer drive gear (page 20-30)

Separate the crankcase halves (page 12-4).

Turn the balancer weight position as shown, then remove the balancer [1] from the right crankcase.

Installation is in the reverse order of removal.



COMBINATION METER

REMOVAL/INSTALLATION

Remove the front visor (page 20-25).

Disconnect the combination meter 9P (Black) connector [1] and speedometer cable [2].

Remove the screws [3] and meter plate [4].

Remove the nuts [5], washers [6] and combination meter assembly [7].

Installation is in the reverse order of removal.

TORQUE:

Combination meter mounting nut:
9.5 N·m (1.0 kgf·m, 7.0 lbf·ft)

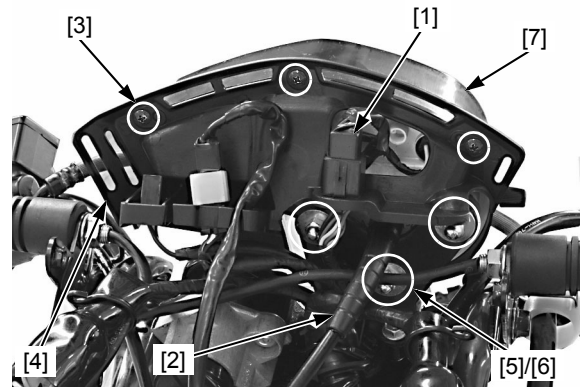

DISASSEMBLY/ASSEMBLY

Disassemble and assemble the combination meter as following illustration.

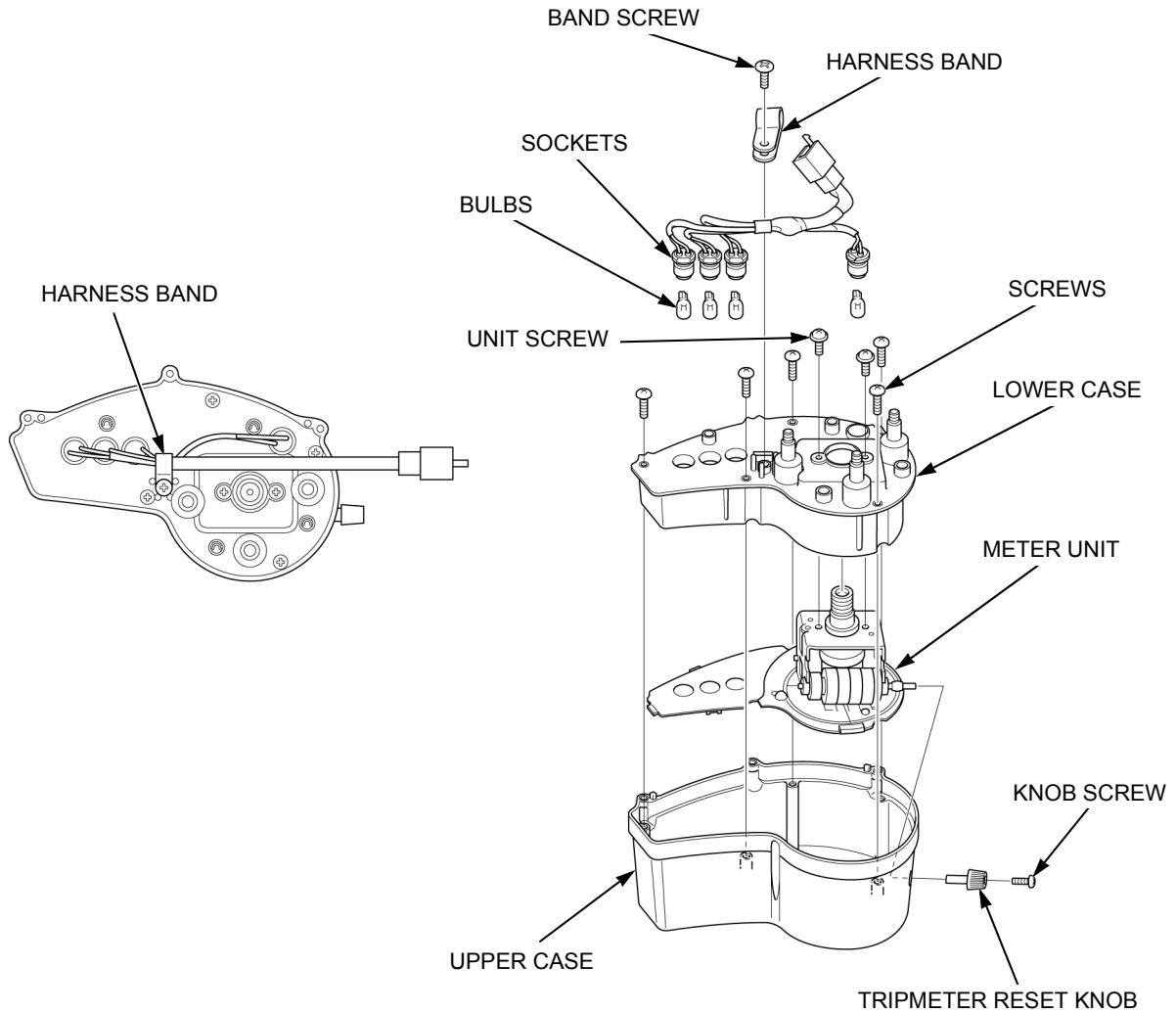

TURN SIGNAL RELAY

REMOVAL/INSTALLATION

Remove the left side cover (page 2-2)

Disconnect the turn signal relay 2P connector [1] and remove the turn signal relay [2].

Installation is in the reverse order of removal.

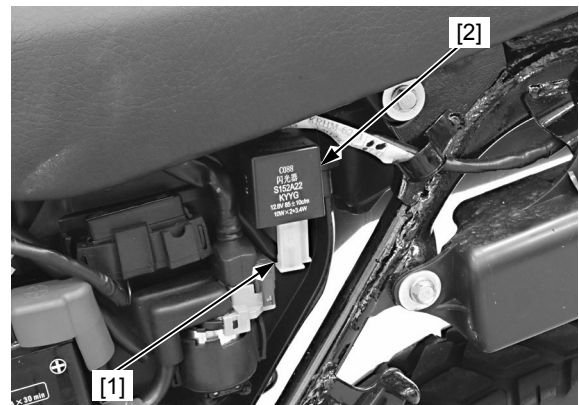

WIRING DIAGRAMS

XR125LEK (DK/III LA TYPES)/XR150LEK (DK/III LA/CO/PH/PE/MX TYPES)

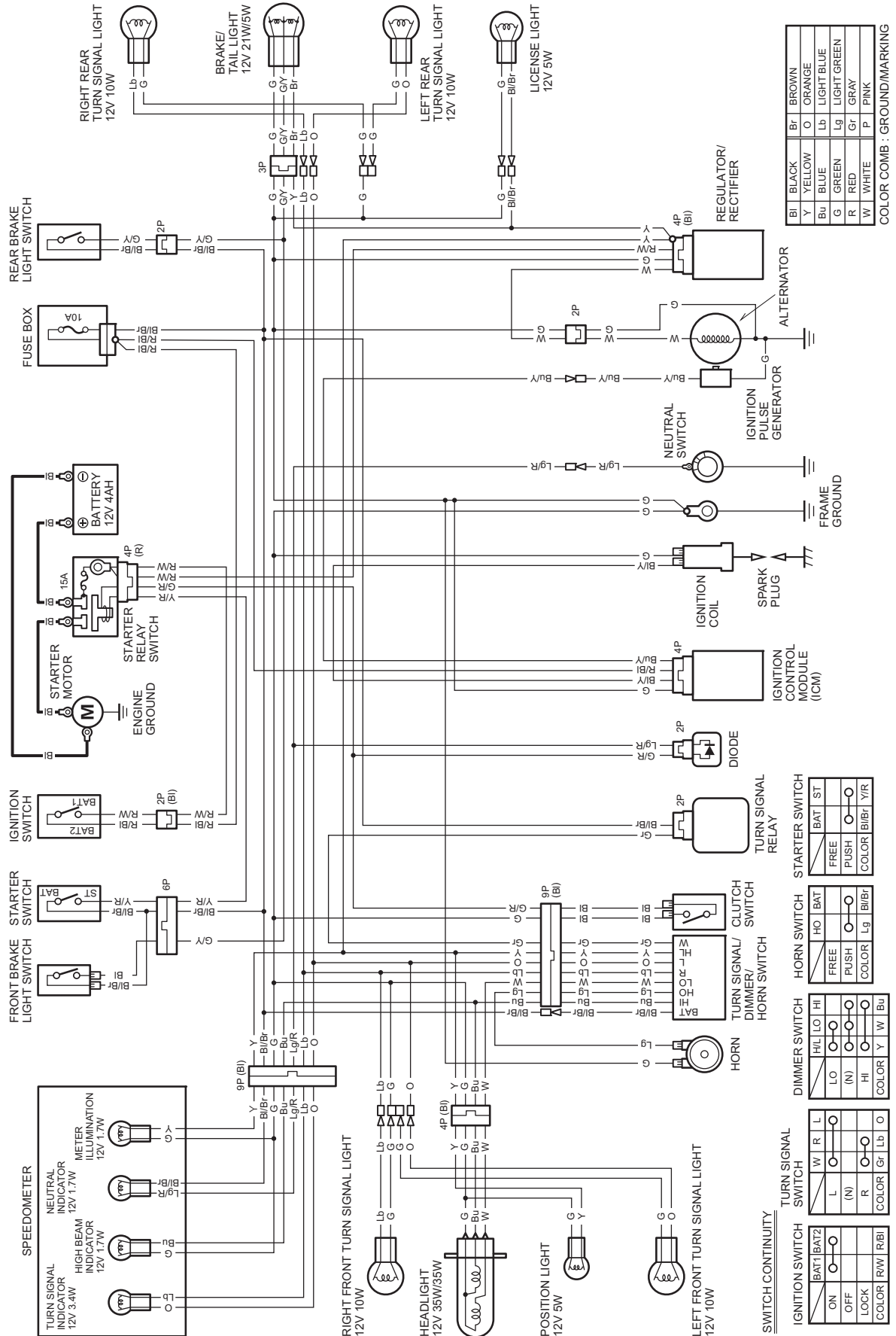

XR125/150LEK, XL125LEK ADDENDUM

XR125LEK (SA TYPE)/XR150LEK (SA/ LA/AG TYPES)

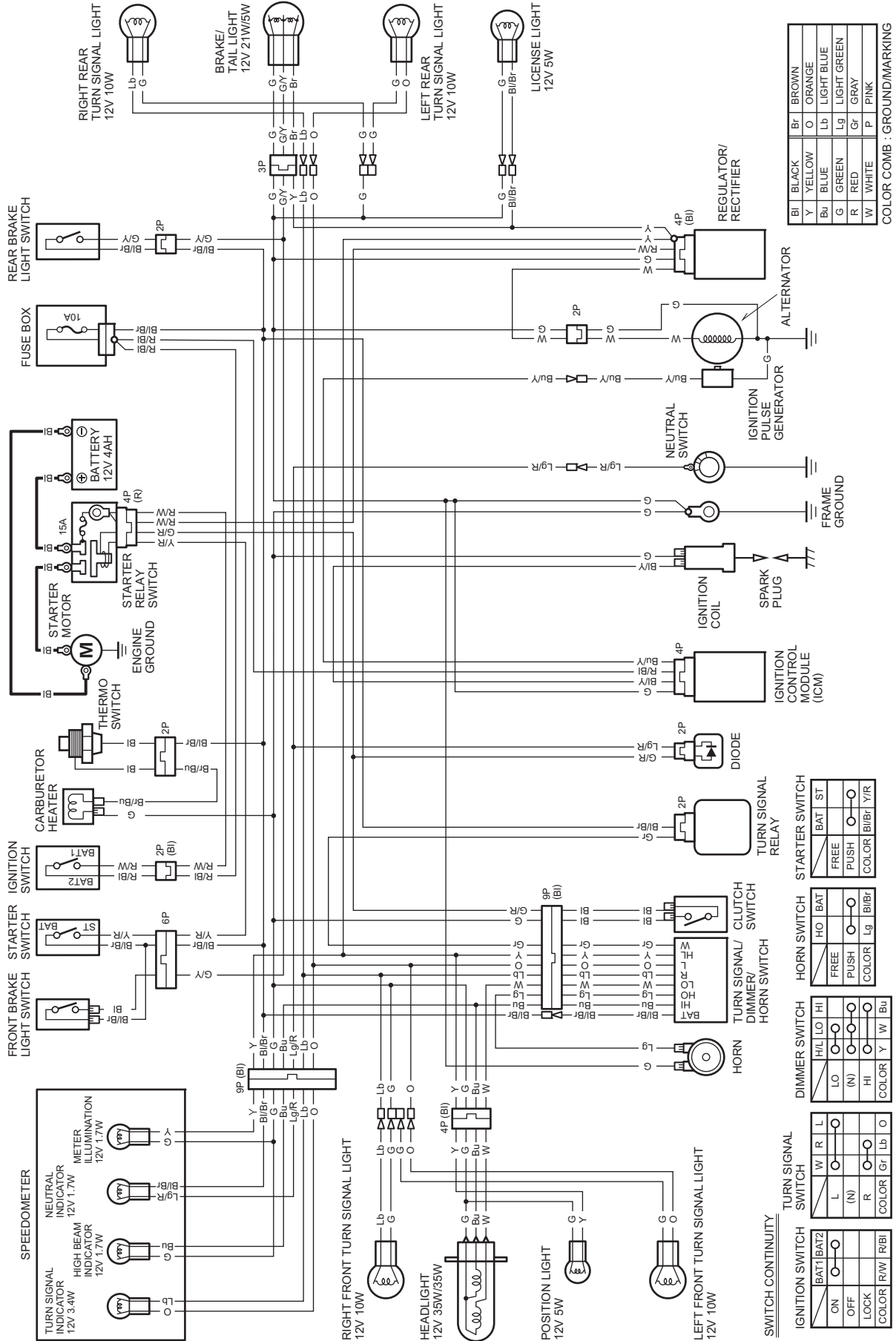

XR150LEK (NZ TYPE)

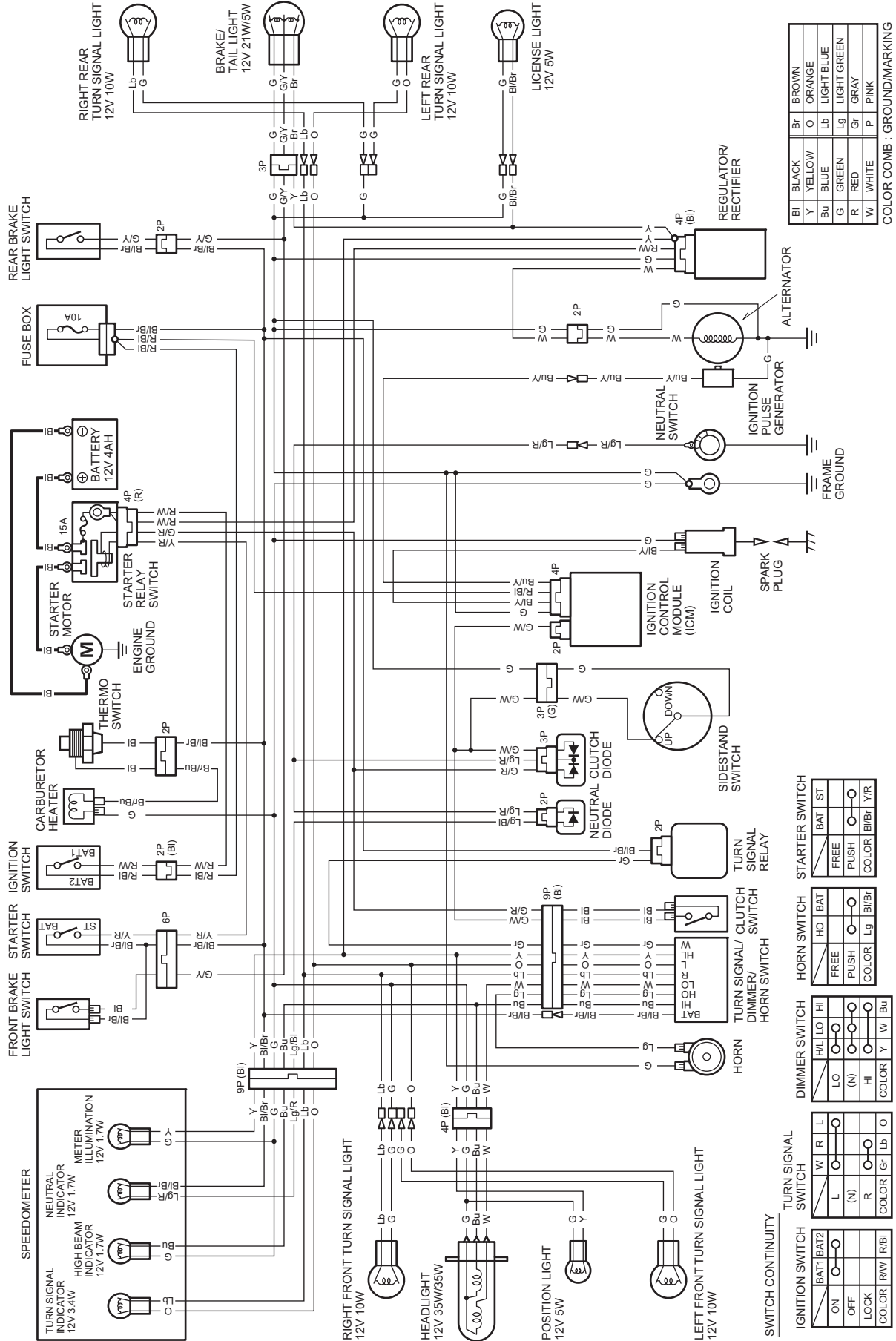

XR125/150LEK, XL125LEK ADDENDUM

XL125LEK (II SA TYPE)

